

Fabri-Valve®

F44 Multi-Port
Knife Gate Valve

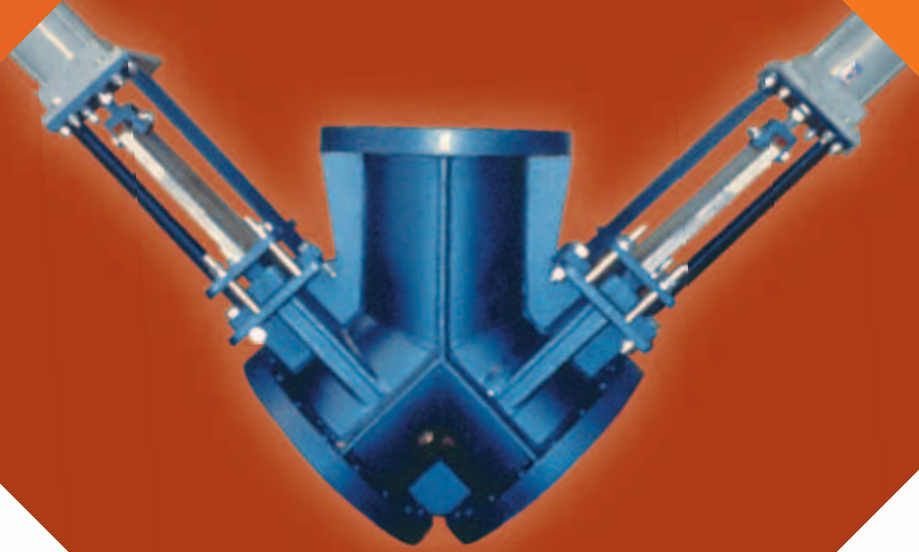

ITT

ENGINEERED FOR LIFE

F44 Multi-Port Knife Gate Valve

The Fabri-Valve Figure F44 Siamese knife gate valve replaces two standard knife gate valves and a pipe "Y". By utilizing a single fabrication, the gates can be placed so they meet right at the intersection of the "Y". This arrangement minimizes the dead leg that occurs in a conventional two valve arrangement as a result of the valves being located several inches from the junction of the pipes.

Fabri-Valve F44, Siamese knife gate valves are available in "Y" and lateral configurations. The angle between the legs and the actuator orientation can be varied to suit specific application needs. The typical Figure F44 has one inlet with two, three or more outlets. However, the figure F44 design platform is extremely flexible; therefore, designs including single or multiple inlets with single or multiple outlets can easily be manufactured.

Specifications

Size Range

3" – 48" (DN 80 – DN 1200)

Pressure Rating

3" – 24": 150 psi (10.3 bar) CWP(cold working pressure)

Above 24": Manufactured per customer's specification.

Temperature Rating

450°F (232°C) Standard Consult factory for applications to 1500°F (816°C) Service temperatures above 400°F (204°C) require high temperature fasteners. Specify service temperature on paperwork.

Face to Face

Per Requirement

Flange Drilling

Per Requirement

Pressure/Temperature Ratings

The table below presents the Maximum Pressure/Temperature Ratings for the metallic components only. When checking pressure/temperature ratings, check the temperature rating and chemical compatibility of the packing material and, if applicable, the resilient seat material. In a majority of knife gate valve designs, the temperature limit or the chemical compatibility of the seat and/or packing material determines the practical pressure/temperature limitations.



Figure F44								
Pressure/Temperature Rating - psi								
Temp °F	Temp °C	304	304L	316	316L	317L	A 36	A516Gr70
		150	66	150	133	150	133	150
200	93	133	114	141	113	135	137	150
250	121	126	108	133	107	128	135	150
300	149	120	102	124	101	121	133	150
350	177	115	98	119	97	116	131	150
400	204	110	93	114	93	112	128	150
450	232	107	90	110	90	108	125	150
500	260	103	87	106	87	105	121	150
600	316	97	82	101	83	100	111	150
700	371	94	80	97	80	96	108	142
800*	427*	89	77	93	77	92		103
900*	482*	87		92				57
1000*	538*	83		90				21
1100*	593*	78		88				
1200*	649*	49		59				
1300*	704*	30		33				
1400*	760*	18		18				
1500*	816*	11		10				

* "R" Series valves have alloy steel wetted parts and a carbon steel exterior.
Standard "R" Series valves are limited to 700°F (371°C); however alternate "R" Series constructions are available to 1000°F (538°C)

NOTE: Each valve is identified by Size-Figure-Series-etc. The "How To Order" section explains the Valve Model Codes.

Dimensions

Valve Size		DIMENSION Inches (mm) F44 with HANDWHEEL													
Inches	DN	A	C	H	J	M	N	P	R	S	T	V	W	Y	AA
3	80	18-1/8 (460)	8 (203)	2-1/2 (64)	7-1/2 (191)	3/4 (19)	4	6 (152)	5 (127)	3-5/8 (92)	1/16 (2)	9/16 (14)	5-1/2 (140)	5-3/4 (1146)	3-1/2 (89)
4	100	20-3/4 (527)	8 (203)	3-1/2 (89)	9 (229)	3/4 (19)	8	7-1/2 (191)	6-3/16 (157)	4-1/8 (105)	1/16 (2)	9/16 (14)	6-1/2 (165)	6-1/4 (159)	4-1/2 (114)
6	150	26-11/16 (678)	10 (254)	6 (152)	11 (279)	7/8 (22)	8	9-1/2 (241)	8-1/2 (216)	4-1/2 (114)	1/16 (2)	11/16 (17)	8 (203)	6-1/4 (159)	7 (178)
8	200	34-3/8 (873)	12 (305)	8 (203)	13-1/2 (343)	7/8 (22)	8	11-3/4 (298)	10-5/8 (270)	4-3/8 (111)	1/16 (2)	13/16 (21)	9 (229)	6-1/4 (159)	9 (229)
10	250	41-5/16 (1049)	16 (406)	10 (254)	16 (406)	1 (25)	12	14-1/4 (362)	12-3/4 (324)	5-3/8 (137)	1/16 (2)	13/16 (21)	11 (279)	6-1/4 (159)	11 (279)
12	300	46-15/16 (1192)	16 (406)	12 (305)	19 (483)	1 (25)	12	17 (432)	15 (381)	5-1/8 (130)	1/8 (3)	7/8 (22)	12 (305)	6-1/2 (165)	13-1/2 (343)
14	350	46-15/16 (1192)	16 (406)	12 (305)	21 (533)	1-1/8 (29)	12	18-3/4 (476)	16-1/4 (413)	7-1/8 (181)	1/8 (3)	7/8 (22)	14 (356)	7-1/2 (191)	13-1/2 (343)
16	400	55-7/16 (1408)	20 (508)	14-1/4 (362)	23-1/2 (597)	1-1/8 (29)	16	21-1/4 (540)	18-1/2 (470)	6-13/16 (173)	1/8 (3)	1 (25)	15 (381)	8-1/4 (210)	15-5/8 (397)
18	450	62-1/2 (1588)	20 (508)	16-1/4 (413)	25 (635)	1-1/4 (32)	16	22-3/4 (578)	21 (533)	7-1/2 (191)	1/8 (3)	1 (25)	16-1/2 (419)	8-1/4 (210)	17-5/8 (448)
20	500	69-1/8 (1756)	20 (508)	18 (457)	27-1/2 (699)	1-1/4 (32)	20	25 (635)	23 (584)	8-3/16 (208)	1/8 (3)	1 (25)	18 (457)	8-3/4 (222)	19-5/8 (498)
24	600	81-15/16 (2081)	20 (508)	22 (559)	32 (813)	1-3/8 (35)	20	29-1/2 (749)	27-1/4 (692)	10 (254)	1/8 (3)	1 (25)	22 (559)	9 (229)	23-5/8 (600)

Reference Dimensions in (parentheses)

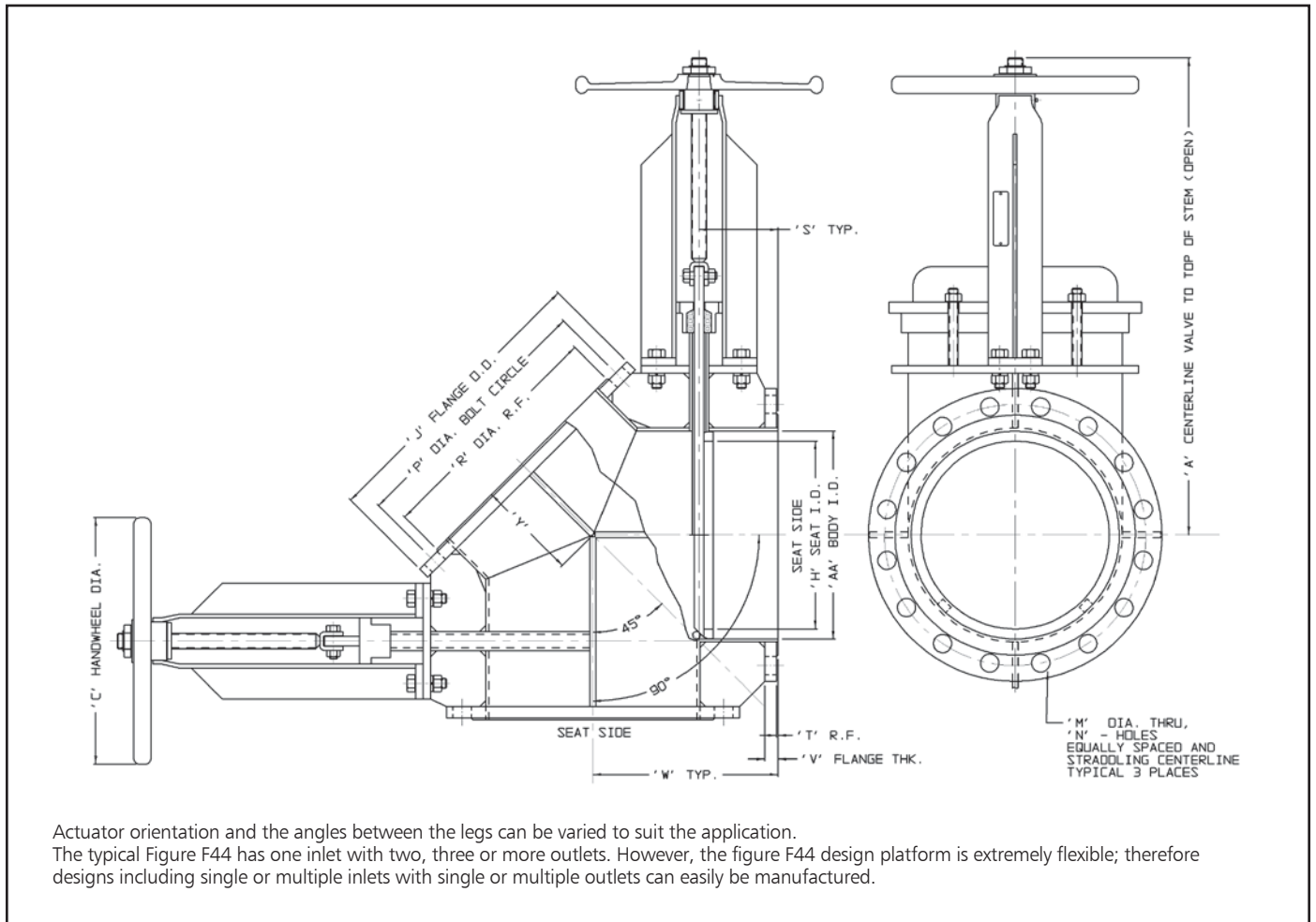

Actuator orientation and the angles between the legs can be varied to suit the application. The typical Figure F44 has one inlet with two, three or more outlets. However, the figure F44 design platform is extremely flexible; therefore designs including single or multiple inlets with single or multiple outlets can easily be manufactured.

Materials of Construction

Part	Materials	
	F44R	F44S
Wetted Body and Chest Components	Heavy wrought stainless steel type 304, 316 or 317L	Heavy wrought stainless steel type 304, 316 or 317L
External Flanges and Stiffeners	Carbon steel	Same as wetted components
Seat	Same as wetted components	Same as wetted components
Gate	Same material as body finished to 63 RMS	Same material as body finished to 63 RMS
Yoke	Carbon steel	304 Stainless steel
Yoke Bolting	Plated steel	Stainless steel
Packing	Acrylic/PTFE/Silicone	Acrylic/PTFE/Silicone
Packing Box	Ductile iron/Carbon steel	316 stainless steel
Packing Box Bolting	Plated steel	Stainless steel
Stem	304 stainless steel	304 stainless steel
Stem Nut	Acid resistant bronze	Acid resistant bronze
Handwheel Retaining Nut	Malleable iron	Stainless steel
Tab Washer	Stainless steel	Stainless steel

Available Options

- "D" Ring Seat
- Hard Faced Integral SS Seats
- Hard Faced Gate Edge
- Hard Gate Material
- Nickel-TFE Coated Gate
- Epoxy Coating
- Thru Drilled Flanges (STD)
- Flush Ports
- Chest Buttons: 6" and larger
- Centerline Buttons
- Backing Ring
- Extra Wedges
- V-Port
- Locking Devices
- E-Z Spin Handwheel
- Live Loaded Packing
- Self-Supporting Yokes
- Bevel Gear
- Chainwheels
- Cylinder Actuators
- Electric Actuators
- Ratchet
- Extended Stems
- Gate Support Strips
- Rod Boots



ENGINEERED FOR LIFE

Engineered Valves, LLC
 1110 Bankhead Ave
 Amory, MS 38821
 662.256.7185
 www.engvalves.com

© 2012 ITT Engineered Valves, LLC

Form F44