

Fabri-Valve®

C45 Ductile Iron
Knife Gate Valve



ITT

ENGINEERED FOR LIFE

C45 Ductile Iron Knife Gate Valve

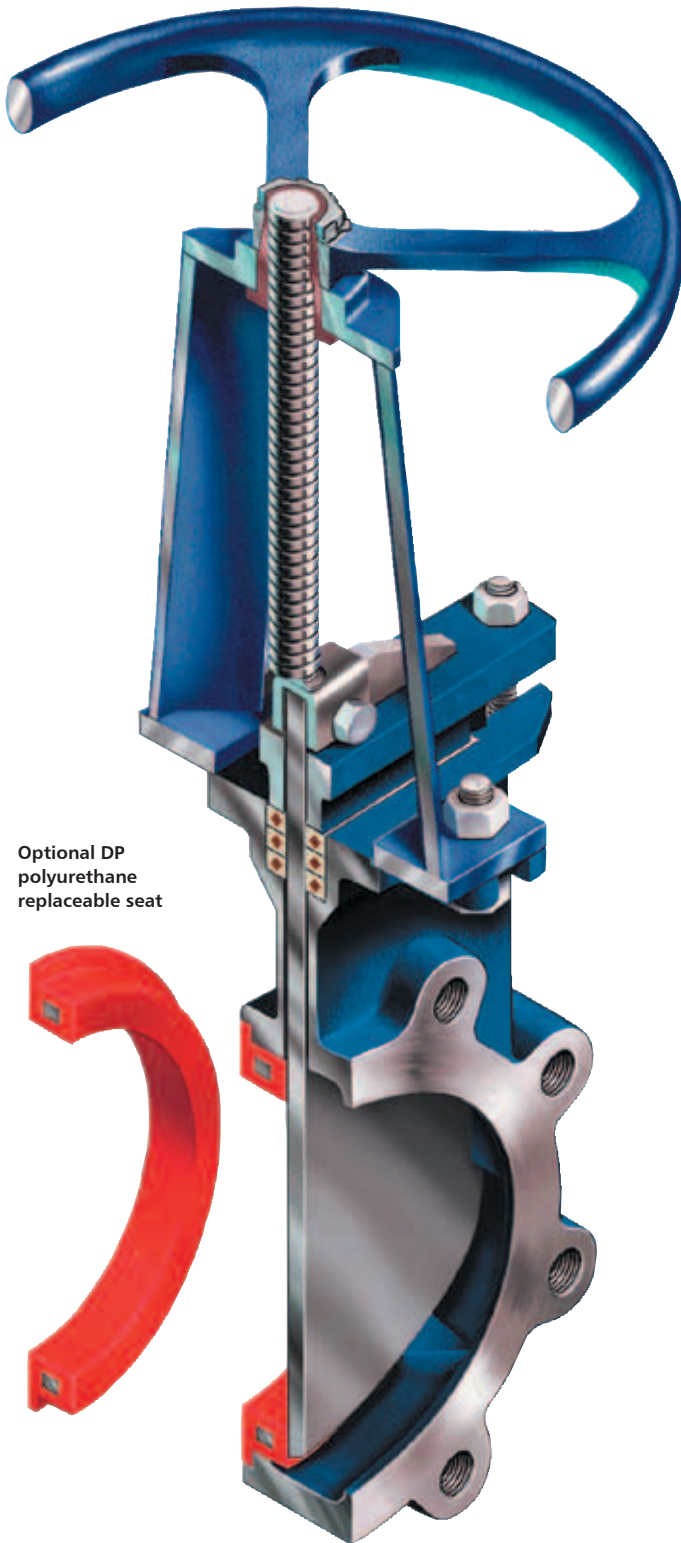

Optional DP polyurethane replaceable seat

The basic Fabri-Valve C45 features a solid ductile iron or carbon steel body with an integral cast metal seat. However, this valve is most often used with the patented, pop-in style replaceable seats, which are available in a variety of rubbers, polyurethane, UHMW-P, TFE, and hard-faced metal. The pop-in seats feature a much larger cross section and seating area than conventional knife gate valve seats thus providing a seating surface far removed from the flow stream. Replaceable seats offer a unique advantage; abrasion resistance, long seat life, and the convenience of easy seat replacement.

All C45 knife gate valves with handwheels include a provision for a locking device.

Caution: (Replaceable soft seats)

Review Fabri-Valve gasket/mating flange recommendations.

Specifications

Size Range

2" – 24"

Pressure Rating

150 psi (10.3 bar) CWP (cold working pressure)

Temperature Rating

Maximum temperature 250°F (121°C).

See Materials of Construction (seat section).

Service temperatures above 400°F (204°C) require high temperature fasteners. Specify service temperature on paperwork.

Flange Drilling

Flat faced ANSI 125/150

Testing

Every Fabri-Valve C45 valve is fully tested prior to shipment.

Testing includes a body shell test, a seat test, and a cycling test to insure proper functioning of moving parts. Additional testing is also available. Please let us know your requirements.

Standard Shell test:

- Hydro test at 1.5 times the rated CWP (cold working pressure) – Zero allowable leakage

Standard Seat test:

- Metal Seat: Hydro test at 40 psi (2.8 bar) and at the rated CWP
- Resilient Seat: Hydro test at 15 psi (1 bar) and rated CWP

Replaceable seat is held in place by the adjacent mating flange.

Shown with energized cored packing.

Standard with 6"(DN 150) and larger Figure C45 valves.

Pressure/Temperature Ratings

The table below is the Maximum Pressure /Temperature Ratings for the metallic components only. When checking pressure/temperature ratings, check the temperature rating and chemical compatibility of the packing material and, if applicable, the resilient seat material. In a majority of knife gate valve designs, the temperature limit or the chemical compatibility of the seat and/or packing material determines the practical pressure/temperature limitations.

Figure C45			
Pressure/Temperature Rating - psi			
Temp		Cast Steel WCB A-216	Cast DI A536 GR 65-45-12
°F	°C		
150	66	150	150
200	93	150	150
250	121	150	147
300	149	150	143
350	177	150	139
400	204	150	135
450	232	150	131
500	260	150	127
600	316	150	119
700	371	142	
800	427	103	
900	482	57	
1000	538	21	

Low Pressure Operation

Metal seated knife gate valves are seat tested at 40 psid (2.8 bar) in the preferred flow direction. When pressure falls below the 40 psid (2.8 bar) test pressure, less force is pushing the gate into the seat, which may result in additional seat leakage. When improved low-pressure shutoff performance is required, optional chest buttons should be specified.

Available Options

- "D" Ring Seat
- Lever Operator
- Dual Seats
- Poly Replaceable Seats
- UHMW Replaceable Seats
- PTFE Replaceable Seats
- Rubber Replaceable Seats
- Hard Faced Gate Edge
- Hard Gate Material
- Nickel-TFE Coated Gate
- Epoxy Coating
- Thru Drilled Flanges
- Flush Ports
- Chest Buttons:
Not available 2" – 6"
- Cast Ni-Hard Deflection Cones: Available sizes 3" – 16"
- Fabricated Deflection Cones
- Locking Devices
- E-Z Spin Handwheel
- Live Loaded Packing
- Self-Supporting Yokes
- Bevel Gear
- Chainwheels
- Cylinder Actuators
- Electric Actuators
- Ratchet
- Extended Stems
- Rod Boots

Shutoff Performance

Metal Seat

- Single integral metal seat
2" – 24" 40cc / minute / inch of valve size
- Single hardfaced replaceable metal seat
2" – 24" 80cc / minute / inch of valve size
- Dual hardfaced replaceable metal seats
Consult factory. All sizes.

Resilient Seat

- Single "D" ring, or single replaceable resilient seat (excluding PTFE)
Zero leakage. All sizes.
- Dual seats
Consult factory. All sizes.
- Single replaceable PTFE seat
Consult factory. All sizes.

Flow Coefficients

The Cv values below represent U.S. gallons per minute 60°F water through a 100% open valve at a pressure drop of 1 psi. The metric equivalent, Kv, is the flow of water at 16°C through the valve in cubic meters per hour at a pressure drop of 1 kg/cm². To convert Cv to Kv, multiply the Cv by 0.8569.

Figure C45 Knife Gate Valves							
Cv Ratings, Port Diameter and Area							
Valve Size In. DN		Standard Port			With Replaceable Poly or Replaceable Rubber seat		
		Cv	Port I.D. Inches	Port Area Sq. In.	Cv	Port I.D. Inches	Port Area Sq. In.
2	50	288	2.00	3.1	288	2.00	3.1
3	75	648	3.00	7.1	648	3.00	7.1
4	100	1,152	4.00	12.6	1,152	4.00	12.6
6	150	2,592	6.00	28.3	2,592	6.00	28.3
8	200	4,608	8.00	50.3	4,608	8.00	50.3
10	250	7,208	10.00	78.5	7,208	10.00	78.5
12	300	10,400	12.00	113.1	10,400	12.00	113.1
14	350	12,650	13.25	137.9	10,080	12.00	113.1
16	400	16,750	15.25	182.6	14,200	14.25	159.5
18	450	21,450	17.25	233.7	18,500	16.25	207.4
20	500	26,700	19.25	291.0	22,700	18.00	254.5
24	600	38,900	23.25	424.6	33,900	22.00	380.1

Dimensions: C45 with Handwheel or Cylinder

Valve Size		TABLE 1 DIMENSION Inches (mm) C45 with HANDWHEEL OR CYLINDER																			
Inches	DN	A			C			D		H	J	K	L	M	N	P	S	W	Z	lb	kg
2	50	HW	2-1/2 CYL	3-1/4 CYL	HW	2-1/2 CYL	3-1/4 CYL	2-1/2 CYL	3-1/4 CYL												
		13-11/16 (348)	18-3/8 (467)	16-7/8 (429)	8 (203)	3 (76)	4 (102)	3/8-18	1/4-18	2 (51)	6 (152)	1/2 (12)	2	5/8-11NC	4	4-3/4 (121)	4 (102)	1-7/8 (48)	9/16 (14)	21	10
3	80	HW	2-1/2 CYL	3-1/4 CYL	HW	2-1/2 CYL	3-1/4 CYL	2-1/2 CYL	3-1/4 CYL												
		16-7/16 (418)	20-7/8 (530)	19-3/8 (492)	8 (203)	3 (76)	4 (102)	3/8-18	1/4-18	3 (76)	7-1/2 (191)	1/2 (12)	2	5/8-11NC	4	6 (152)	4 (102)	2 (51)	5/8 (16)	26	12
4	100	HW	3-1/4 CYL	4 CYL	HW	3-1/4 CYL	4 CYL	3-1/4 CYL	4 CYL												
		19-3/16 (487)	22-1/8 (562)	22-7/8 (581)	8 (203)	4 (76)	4-1/2 (114)	1/4-18	3/8-18	4 (102)	9 (229)	1/2 (12)	2	5/8-11NC	8	7-1/2 (191)	4 (102)	2 (51)	5/8 (16)	31	14
6	150	HW	4 CYL	6 CYL	HW	4 CYL	6 CYL	4 CYL	6 CYL												
		25-5/16 (643)	28-7/8 (733)	29-1/4 (743)	10 (254)	4-1/2 (114)	6-1/2 (165)	3/8-18	3/8-18	6 (152)	11 (279)	9/16 (14)	2	3/4-10NC	8	9-1/2 (241)	7-3/8 (187)	2-1/4 (57)	3/4 (19)	52	24
8	200	HW	6 CYL	8 CYL	HW	6 CYL	8 CYL	6 CYL	8 CYL												
		32-5/8 (829)	35-13/16 (910)	36-5/16 (922)	12 (305)	6-1/2 (165)	8-5/8 (219)	3/8-18	3/8-18	8 (203)	13-1/2 (343)	5/8 (16)	2	3/4-10NC	8	11-3/4 (298)	7-3/8 (187)	2-3/4 (70)	1 (25)	105	48
10	250	HW	8 CYL	10 CYL	HW	8 CYL	10 CYL	8 CYL	10 CYL												
		37-3/4 (959)	41-7/16 (1072)	42-3/16 (1072)	16 (406)	8-5/8 (219)	10-7/8 (276)	3/8-18	1/2-14	10 (254)	16 (406)	5/8 (16)	4	7/8-9NC	12	14-1/4 (362)	7-3/8 (187)	2-3/4 (70)	1 (25)	145	66
12	300	HW	8 CYL	10 CYL	HW	8 CYL	10 CYL	8 CYL	10 CYL												
		44-9/16 (1132)	48 (1219)	48-3/4 (1238)	16 (406)	8-5/8 (219)	10-7/8 (276)	3/8-18	1/2-14	12 (305)	19 (483)	5/8 (16)	4	7/8-9NC	12	17 (432)	7-1/2 (191)	3 (76)	1 (25)	205	93
14	350	HW	12 CYL	14 CYL	HW	12 CYL	14 CYL	12 CYL	14 CYL												
		49-1/4 (1251)	54-1/16 (1373)	55-3/16 (1402)	20 (508)	12-3/4 (324)	14-3/4 (375)	1/2-14	3/4-14	13-1/4 (337)	21 (533)	21/32 (17)	4	1-8NC	12	18-3/4 (476)	7-3/4 (197)	3 (76)	1 (25)	235	107
16	400	HW	12 CYL	14 CYL	HW	12 CYL	14 CYL	12 CYL	14 CYL												
		56-1/2 (1435)	61-1/16 (1551)	62-3/16 (1580)	20 (508)	12-3/4 (324)	14-3/4 (375)	1/2-14	3/4-14	15-1/4 (387)	23-1/2 (597)	25/32 (20)	6	1-8NC	16	21-1/4 (540)	11-1/4 (286)	3-1/2 (89)	1-1/4 (32)	390	145
18	450	HW	12 CYL	14 CYL	HW	12 CYL	14 CYL	12 CYL	14 CYL												
		63-5/16 (1608)	66-1/2 (1689)	67-5/8 (1718)	20 (508)	12-3/4 (324)	14-3/4 (375)	1/2-14	3/4-14	17-1/4 (438)	25 (635)	3/4 (19)	6	1-1/8-7NC	16	22-3/4 (578)	11-1/4 (286)	3-1/2 (89)	1-3/8 (35)	515	177
20	500	HW	14 CYL	16 CYL	HW	14 CYL	16 CYL	14 CYL	16 CYL												
		68-5/8 (1743)	72-15/16 (1853)	73-7/16 (1865)	20 (508)	14-3/4 (375)	17 (432)	3/4-14	3/4-14	19-1/4 (489)	27-1/2 (699)	1-1/8 (29)	8	1-1/8-7NC	20	25 (635)	14 (356)	4-1/2 (114)	1-1/2 (38)	690	234
24	600	HW	16 CYL	18 CYL	HW	16 CYL	18 CYL	16 CYL	18 CYL												
		79-13/16 (2027)	84-11/16 (2151)	86-5/8 (2200)	20 (508)	17 (432)	19 (483)	3/4-14	3/4-14	23-1/4 (591)	32 (813)	1-1/16 (27)	8	1-1/4-7NC	20	29-1/2 (749)	14-1/8 (359)	4-1/2 (114)	1-1/2 (38)	923	313

* Valve and Handwheel

Reference Dimensions in (parentheses)

C45 with Handwheel or Cylinder

Refer to table on page 4 for dimensions

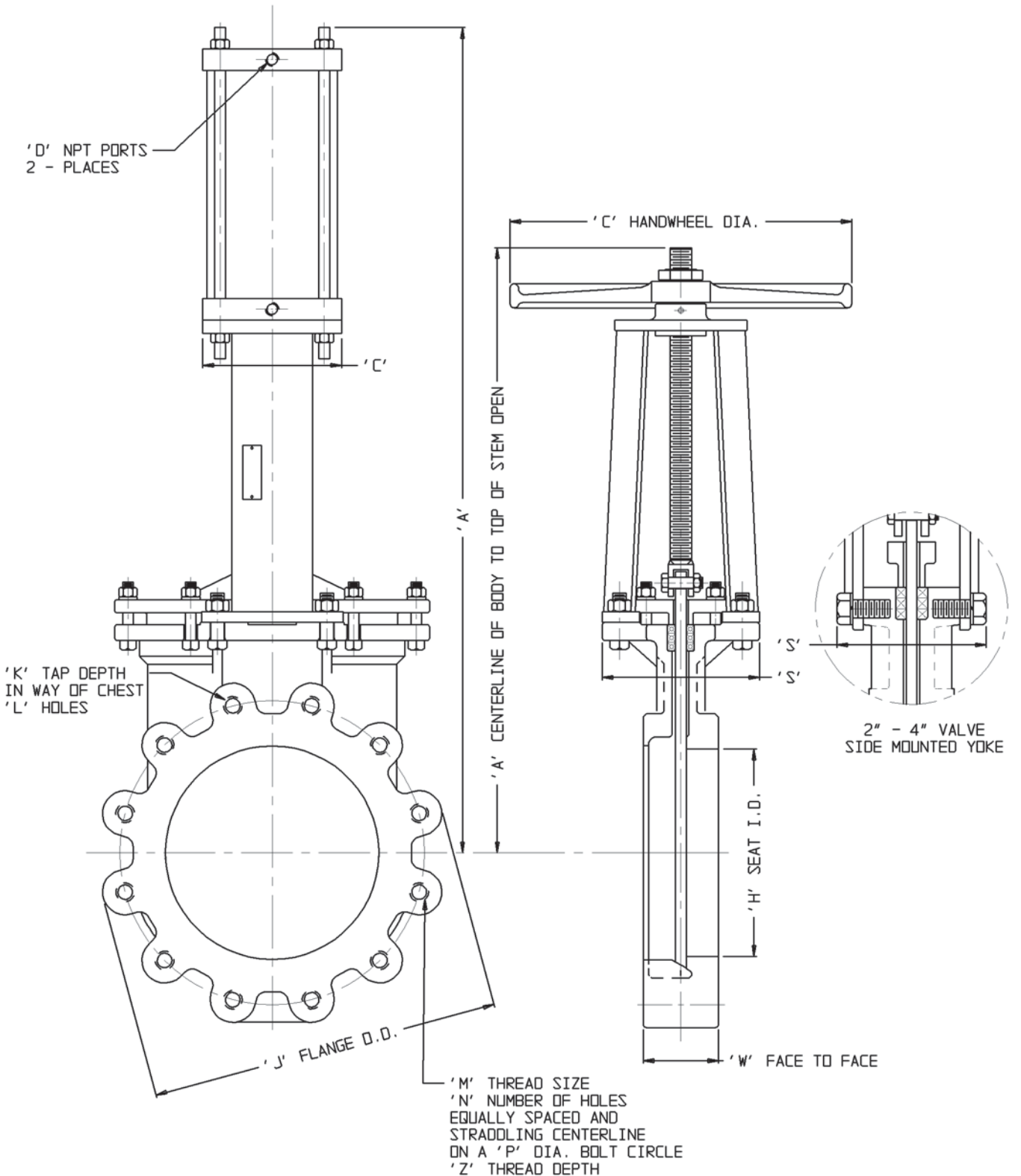

Materials of Construction

Part	Materials
Body and Chest	Ductile iron
Flanges	Ductile iron
Seat Rating	Integral metal, D-ring, or replaceable With integral seat 500°F (260°C) With RW seat 140°F (60°C) With RP seat 180°F (82°C) With RH seat 550°F (288°C) standard, 650°F (343°C) with special packing. With RT seat 400°F (204°C)
Gate	304 stainless steel finished to 63 RMS
Yoke	Carbon steel
Yoke Bolting	Plated steel
Packing	Acrylic/PTFE/silicone ¹
Packing Follower	Ductile iron w/plated steel bolting
Stem	304 stainless steel
Stem Nut	Acid resistant bronze
Lubrication Fitting	Plated steel
Handwheel	Cast iron
Handwheel Retaining Nut	Malleable iron
Tab Washer	Stainless steel

¹Energized cored packing is standard with 6" (DN150) and larger C45 valves

Dimensions: C45 with Bevel Gear

Valve Size		TABLE 2 DIMENSION Inches (mm) C45 with BEVEL GEAR														
Inches	DN	A	B	C	D	E	H	J	K	L	M	N	P	S	W	Z
6	150	25-5/16 (643)	19-11/16 (500)	12 (305)	12-3/8 (314)	6-1/2 (165)	6 (152)	11 (279)	9/16 (14)	2	3/4-10NC	8	9-1/2 (241)	7-3/8 (187)	2-1/4 (57)	3/4 (19)
8	200	32-15/16 (837)	24-5/8 (625)	12 (305)	12-3/8 (314)	6-1/2 (165)	8 (203)	13-1/2 (343)	5/8 (16)	2	3/4-10NC	8	11-3/4 (298)	7-3/8 (187)	2-3/4 (70)	1 (25)
10	250	38-1/16 (967)	27-5/16 (694)	12 (305)	12-3/8 (314)	6-1/2 (165)	10 (254)	16 (406)	5/8 (16)	4	7/8-9NC	12	14-1/4 (362)	7-3/8 (187)	2-3/4 (70)	1 (25)
12	300	44-9/16 (1132)	31-13/16 (808)	12 (305)	12-3/8 (314)	6-1/2 (165)	12 (305)	19 (483)	5/8 (16)	4	7/8-9NC	12	17 (432)	7-1/2 (191)	3 (76)	1 (25)
14	350	49-13/16 (1265)	34-3/4 (883)	12 (305)	12-3/8 (314)	6-1/2 (165)	13-1/4 (337)	21 (533)	21/32 (17)	4	1-8NC	12	18-3/4 (476)	7-3/4 (197)	3 (76)	1 (25)
16	400	56-9/16 (1437)	40-3/8 (1026)	12 (305)	12-1/16 (306)	6-1/2 (165)	15-1/4 (387)	23-1/2 (597)	25/32 (20)	6	1-8NC	16	21-1/4 (540)	11-1/4 (286)	3-1/2 (89)	1-1/4 (32)
18	450	63-5/16 (1608)	43-13/16 (1113)	12 (305)	12-1/16 (306)	6-1/2 (165)	17-1/4 (438)	25 (635)	3/4 (19)	6	1-1/8-7NC	16	22-3/4 (578)	11-1/4 (286)	3-1/2 (89)	1-3/8 (35)
20	500	68-5/8 (1543)	47-15/16 (1218)	12 (305)	12-1/16 (306)	6-1/2 (165)	19-1/4 (489)	27-1/2 (699)	1-1/8 (29)	8	1-1/8-7NC	20	25 (635)	14 (356)	4-1/2 (114)	1-1/2 (38)
24	600	79-7/8 (2029)	55-3/16 (1402)	12 (305)	12-1/16 (306)	6-1/2 (165)	23-1/4 (591)	32 (813)	1-1/16 (27)	8	1-1/4-7NC	20	29-1/2 (749)	14-1/8 (359)	4-1/2 (114)	1-1/2 (81)

Reference dimensions in (parentheses)

6" - 14" valves have a bevel gear ratio of 3:1

16" - 24" valves have a bevel gear ratio of 4:1

C45 with Bevel Gear

Refer to table on page 6 for dimensions

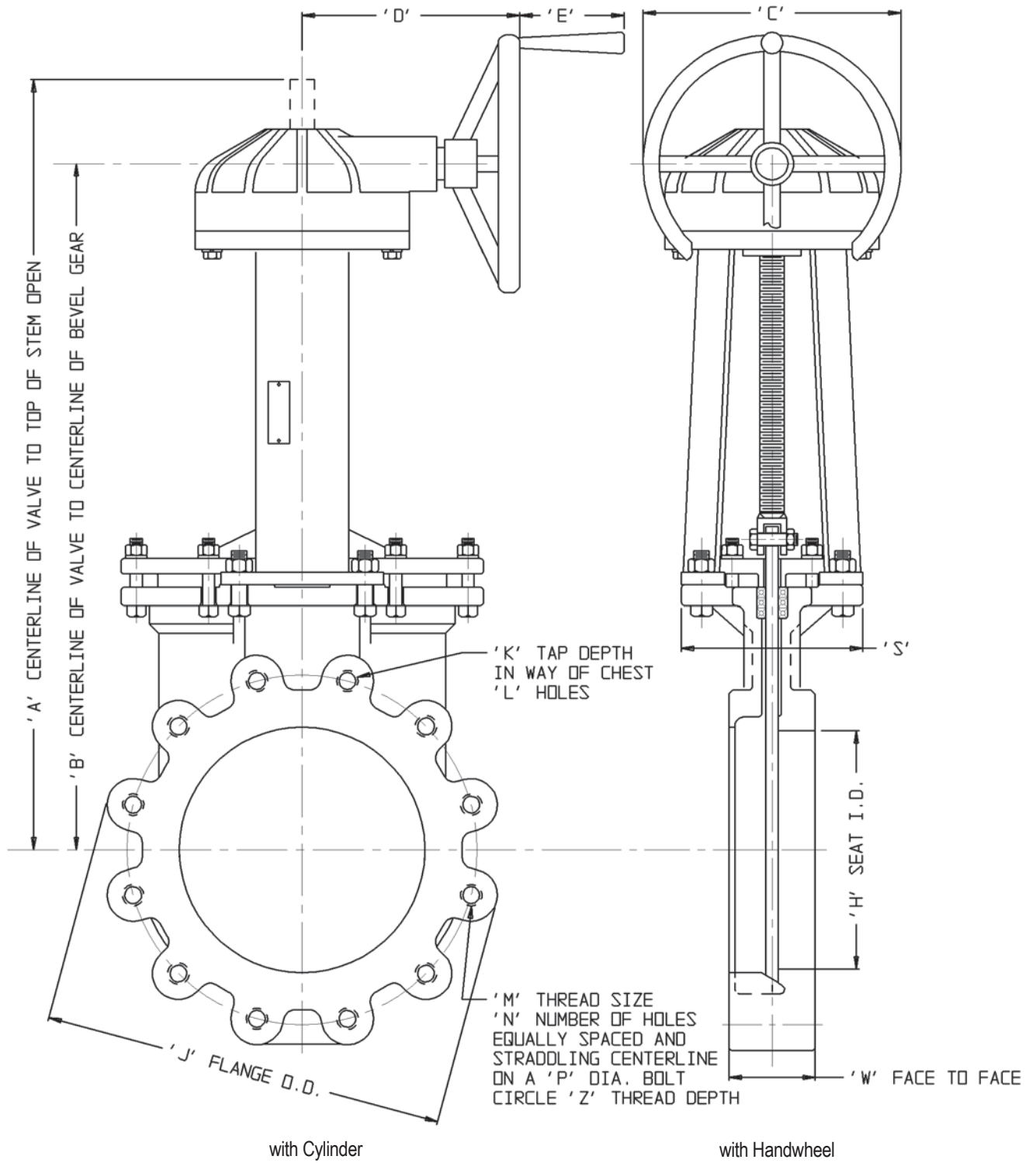



ENGINEERED FOR LIFE

Engineered Valves, LLC
1110 Bankhead Ave
Amory, MS 38821
662.256.7185
www.engvalves.com

© 2012 ITT Engineered Valves, LLC

Form C45