

Fabri-Valve®

## Recycle / Reject Valve

Designed specifically to address problems found in recycle & rejects services

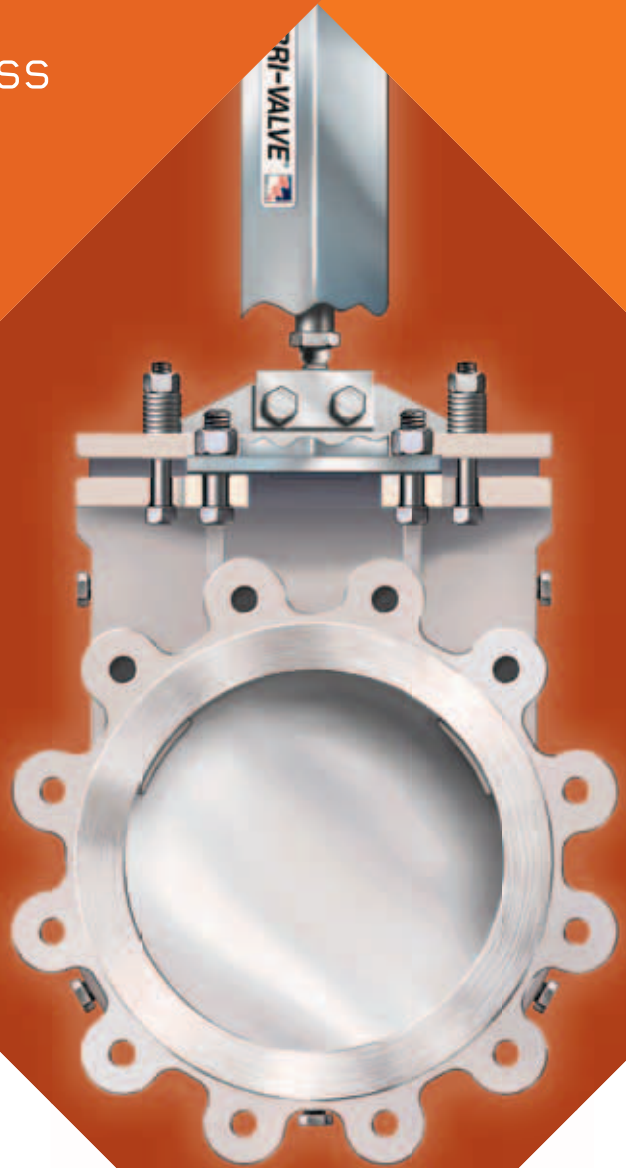

**ITT**

ENGINEERED FOR LIFE

# Tough services demand tough valves.

Recycle and rejects services are tough on valves. Over the years many new, and often expensive valve configurations have been thrown at these applications without much success. Now, Engineered Process Solutions offers a specially configured knife gate valve that solves the valve problems common to these services.

## Bring It On!

Designed to address the specific service problems found in recycle and rejects service, the Fabri-Valve Figure C42 is configured to minimize the effects of the following service problems:

- **Physical damage of the sealing surfaces** (gate and seat) due to wire, staples and other debris, resulting in unacceptable sealing degradation.

- **Clogging** due to accumulation of wire, staples or other debris that is compacted into the bottom of the valve, resulting in the failure of the valve to close completely, and excessive leakage.
- **Poor packing performance** due to damage of the gate surface, abrasion and high cyclic conditions.

*Fabri-Valve* Figure C42 solves these problems by selecting tough materials for the components that face the tough conditions. The seat is protected on both the ID and face by a heavy overlay of special impact resistant alloy. The gate is precision ground from a very hard corrosion resistant alloy. Together they provide an effective, durable shear to cut through wire, staples and other debris.

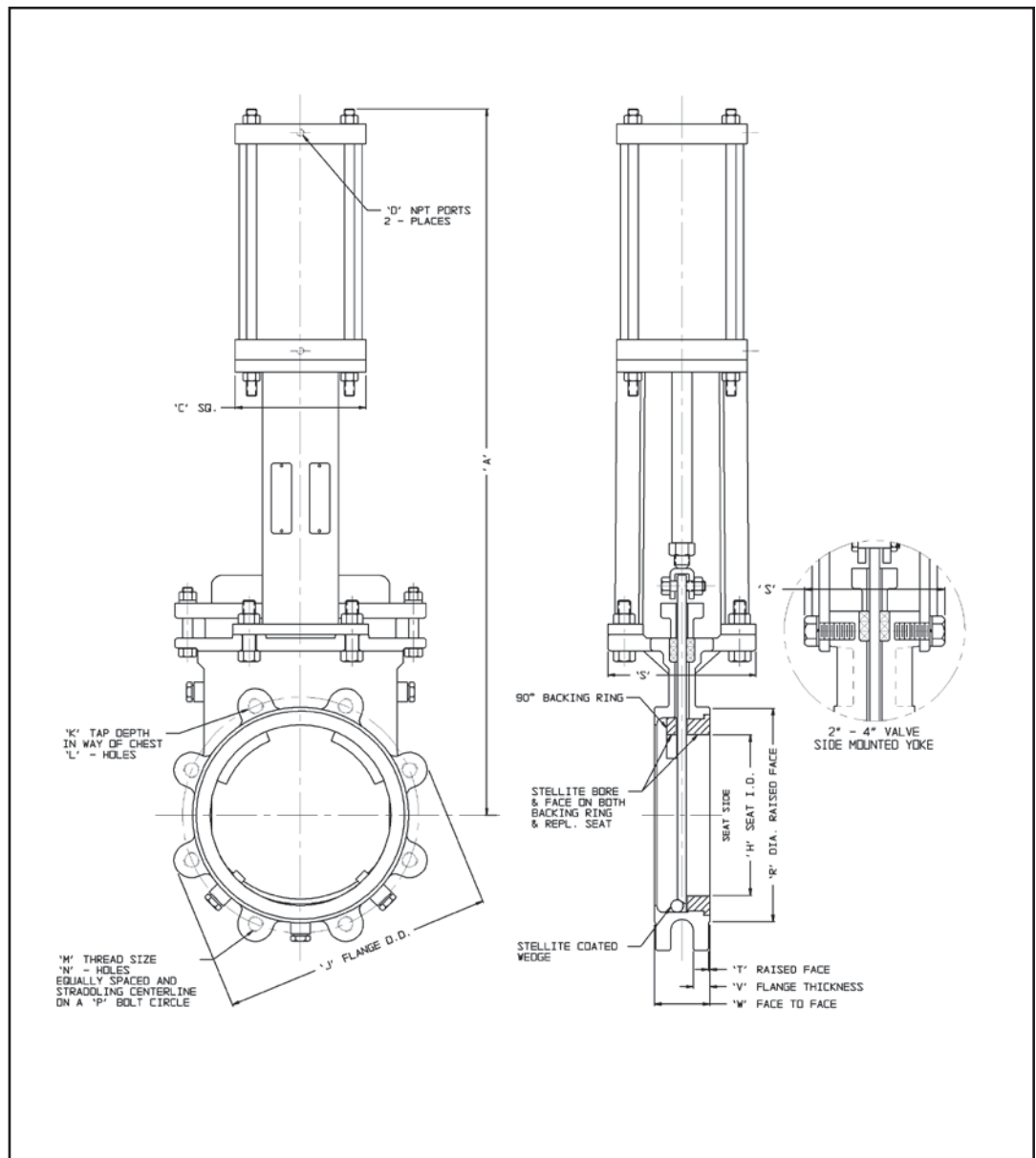

# Dimensions

Valve Size		DIMENSION Inches (mm) C42 with CYLINDER														Weight	
Inches	DN	A	C	D	H	J	K	L	M	N	P	R	S	T	V	W	lb (kg)
2	50	4 CYL	4 CYL	4 CYL	2 (51)	6 (152)	3/8 (10)	2	5/8-11NC	4	4-3/4 (121)	3-5/8 (92)	4 (102)	1/16 (2)	9/16 (14)	1-7/8 (48)	35 (15.8)
		17-3/8 (441)	4-1/2 (114)	3/8-18													
3	80	5 CYL	5 CYL	5 CYL	3 (76)	7-1/2 (191)	13/32 (10)	2	5/8-11NC	4	6 (152)	5 (127)	4 (102)	1/16 (2)	9/16 (14)	2 (51)	53 (24)
		20-1/8 (511)	5-1/2 (140)	3/8-18													
4	100	5 CYL	5 CYL	5 CYL	4 (102)	9 (229)	13/32 (10)	2	5/8-11NC	8	7-1/2 (191)	6-3/16 (157)	4 (102)	1/16 (2)	11/16 (17)	2 (51)	58 (26.5)
		22-7/8 (581)	5-1/2 (140)	3/8-18													
6	150	8 CYL	8 CYL	8 CYL	6 (152)	11 (279)	7/16 (11)	2	3/4-10NC	8	9-1/2 (241)	8-1/2 (216)	7-3/8 (187)	1/16 (2)	5/8 (16)	2-1/4 (57)	129 (58.5)
		29-3/4 (756)	8-5/8 (219)	3/8-18													
8	200	10 CYL	10 CYL	10 CYL	8 (203)	13-1/2 (343)	5/8 (16)	2	3/4-10NC	8	11-3/4 (298)	10-5/8 (270)	7-3/8 (187)	1/16 (2)	13/16 (21)	2-3/4 (70)	230 (104.6)
		37-1/16 (941)	10-7/8 (276)	1/2-14													
10	250	10 CYL	10 CYL	10 CYL	10 (254)	16 (406)	1/2 (13)	4	7/8-9NC	12	14-1/4 (362)	12-3/4 (324)	7-3/8 (187)	1/8 (3)	15/16 (24)	2-3/4 (70)	268 (122)
		42-3/16 (1072)	10-7/8 (276)	1/2-14													
12	300	12 CYL	12 CYL	12 CYL	12 (305)	19 (483)	1/2 (13)	4	7/8-9NC	12	17 (432)	15 (381)	7-1/2 (191)	3/16 (5)	1 (25)	3 (76)	373 (169.6)
		49-1/4 (1251)	12-3/4 (324)	1/2-14													
14	350	14 CYL	14 CYL	14 CYL	13-1/4 (337)	21 (533)	7/16 (11)	4	1-8NC	12	18-3/4 (476)	16-1/4 (413)	7-3/4 (197)	3/16 (5)	15/16 (24)	3 (76)	523 (237.9)
		55-3/16 (1402)	14-3/4 (375)	3/4-14													
16	400	14 CYL	14 CYL	14 CYL	15-1/4 (387)	23-1/2 (597)	9/16 (14)	6	1-8NC	16	21-1/4 (540)	18-1/2 (470)	11-1/4 (286)	3/16 (5)	1-1/16 (27)	3-1/2 (89)	558 (253.5)
		62-3/16 (1580)	14-3/4 (375)	3/4-14													
18	450	16 CYL	16 CYL	16 CYL	17-1/4 (438)	25 (635)	5/8 (16)	6	1-1/8-7NC	16	22-3/4 (578)	21 (533)	11-1/4 (286)	3/16 (5)	1-1/16 (27)	3-1/2 (89)	803 (364.9)
		68-1/8 (1730)	17 (432)	3/4-14													
20	500	16 CYL	16 CYL	16 CYL	19-1/4 (489)	27-1/2 (699)	29/32 (23)	8	1-1/8-7NC	20	25 (635)	23 (584)	14 (356)	3/16 (5)	1-3/16 (30)	4-1/2 (114)	941 (427.8)
		73-7/16 (1865)	17 (432)	3/4-14													
24	600	18 CYL	18 CYL	18 CYL	23-1/4 (591)	32 (813)	13/16 (21)	8	1-1/4-7NC	20	29-1/2 (749)	27-1/4 (692)	14-1/8 (359)	3/16 (5)	1-5/16 (33)	4-1/2 (114)	1318 (599.1)
		86-5/8 (2200)	19 (483)	3/4-14													

Larger sizes available

Reference Dimensions in (parentheses).

## High performance and easy installation.

A specially designed, heavy duty, open bore, cast stainless steel valve body is designed to eliminate the tight cavities that promote the compacting of staples and wire. Instead the wire, staples and debris are sheared, and the pieces fall away. In addition to acting as an effective shear, the hard gate also resists surface damage which preserves packing performance. Special abrasion resistant packing and live loading of the packing follower promote high cycle packing performance. The self-supporting yokes prevent actuator alignment problems and make installation a snap.

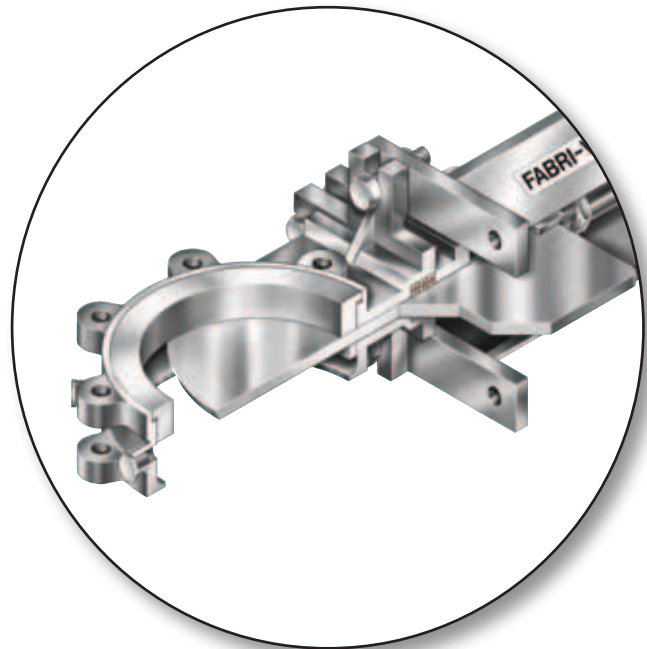

## The Fabri-Valve C42, a tough valve, *not* a tough choice.

It is also simple, effective, economical and backed by experience. Contact your local ITT distributor for more information on how the Fabri-Valve Figure C42 will help solve your recycle/rejects problems, and keep your operation running smoothly.

### Optional Vortex Breaker

The Vortex Breaker is a hard-faced replaceable seat with hardened lugs on the internal diameter, which disrupt the vortex adjacent to the gate face. (Solves severe valve wear problems caused by sand and grit bearing vortices).

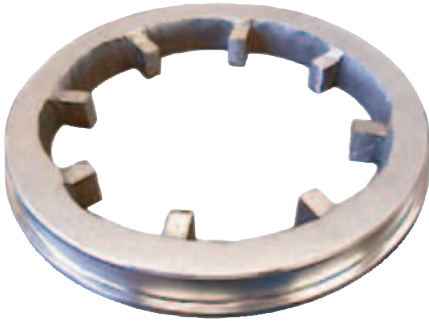

ENGINEERED FOR LIFE

Engineered Valves, LLC  
1110 Bankhead Ave  
Amory, MS 38821  
662.256.7185  
www.engvalves.com

© 2012 ITT Engineered Valves, LLC

Form C42