

Fabri-Valve®

C105 Polyurethane
Knife Gate Valve

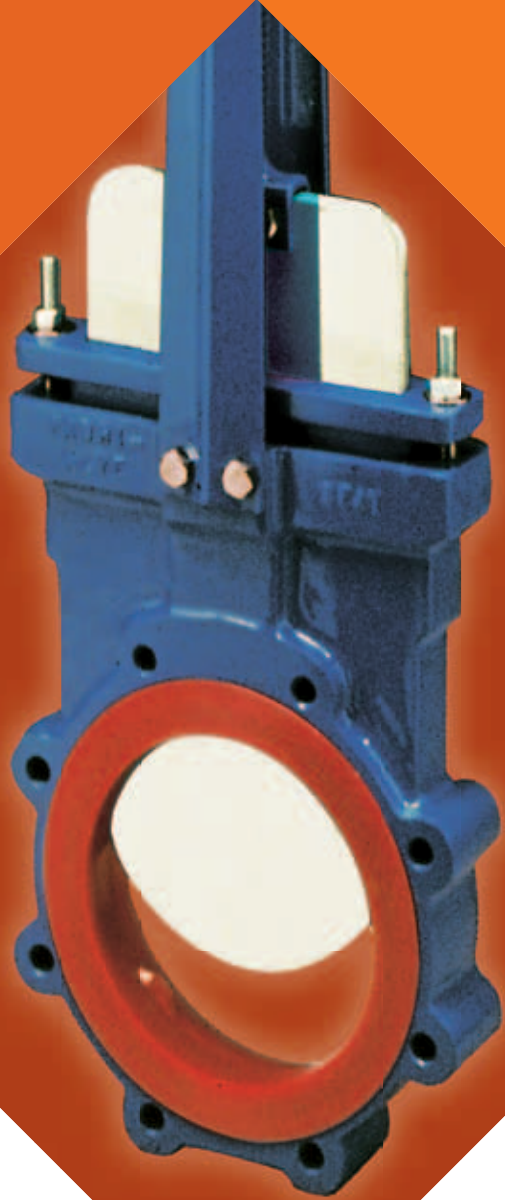

ITT

ENGINEERED FOR LIFE

C105 Polyurethane Knife Gate Valve

Abrasion resistance at its best with a unique one piece polyurethane liner throughout the body and chest. Stainless steel gate, with an option for special alloy gates. The patented, replaceable “pop-in” steel reinforced polyurethane seat is standard.

Pressure/Temperature Ratings

Figure C105	
Pressure-Temperature Rating	
180°F max	150psi(10.3 bar)

Consult Factory for Temperatures up to 220°F(104°C)

Flow Coefficients

The Cv values below represent U.S. gallons per minute 60°F water through a 100% open valve at a pressure drop of 1 psi. The metric equivalent, Kv, is the flow of water at +16°C through the valve in cubic meters per hour at a pressure drop of 1 kg/cm2. To convert Cv to Kv, multiply the Cv by 0.8569.

Figure 105 4"-12" Knife Gate Valves				
Cv Ratings, Port Diameter and Area				
Valve Size		Standard Port Replaceable Polyurethane		
In.	DN	Cv	Port I.D Inches	Port Area Sq. In.
4	100	1,152	4.00	12.6
6	150	2,592	6.00	28.3
8	200	4,608	8.00	50.3
10	250	7,208	10.00	78.5
12	300	10,400	12.00	113.1

Available Options

- Bevel Gear
- Chainwheels
- Cylinder Actuators
- Electric Actuators
- E-Z Spin Handwheel
- Lever Operator
- Ratchet
- Epoxy Coating
- Extended Stems
- Hard Faced Gate Edge
- Hard Gate Material
- Nickel-TFE Coated Gate
- Live-Load Packing
- Locking Devices
- Rod Boots
- Self-Supporting Yokes
- Thru Drill Flanges

Specifications

Size Range

4"-12"

Pressure Rating

150 psi (10.3 bar) CWP(cold working pressure)

Temperature Rating

180°F(82°C). Consult factory for temperatures up to 220°F(104°C)

Flange Drilling

Flat Face ANSI 125/150

Testing

Every Fabri-Valve Figure C105 valve is fully tested prior to shipment. Testing includes a body shell test, a seat test, and a cycling test to insure proper functioning of moving parts. Additional testing is also available. Please let us know your requirements.

Standard Shell test:

- Hydro test at 1.5 times the rated CWP (cold working pressure) – Zero allowable leakage

Standard Seat test:

- Resilient Seat: Hydro test at 15 psi and rated CWP

Shutoff Performance

- Resilient Seat: Polyurethane
Zero leakage. All sizes.

Materials of Construction

Parts	Materials
Body	Cast iron 4"-12"
Body Liner	Molded Polyurethane, 180°F (82°C)
Seat	Steel-reinforced Replaceable Polyurethane
Gate	304 stainless steel
Yoke	Carbon steel
Yoke Fasteners	Plated steel
Packing	TFE/Graphite
Packing Follower	Carbon steel/Ductile Iron
Follower Bolting	Plated steel
Stem	304 stainless steel
Stem Nut	Acid Resistant Bronze
Lubrication Fitting	Plated steel
Handwheel	Cast Iron
Handwheel Retaining Nut	Malleable iron
Tab Washer	Stainless steel
Travel stop	Plated steel
Glide Ring	304 stainless steel

Dimensions

Valve Size		DIMENSION Inches (mm) with HANDWHEEL OR CYLINDER																		
Inches	DN	A			C			D		H	J	K	L	M	N	P	S	W	Z	AA
4	100	HW	3-1/4 CYL	4 CYL	HW	3-1/4 CYL	4 CYL	3-1/4 CYL	4 CYL	4 (102)	9 (229)	5/8 (16)	2	5/8-11NC	8	7-1/2 (191)	4 (102)	2 (51)	3/4 (19)	4-5/8 (117)
		20-3/16 (513)	21-1/8 (537)	21-5/8 (5549)	8 (203)	4 (102)	4-1/2 (114)	1/4-18	3/8-18											
6	150	HW	4 CYL	6 CYL	HW	4 CYL	6 CYL	4 CYL	6 CYL	6 (152)	11 (279)	5/8 (16)	2	3/4-10NC	8	9-1/2 (241)	4-3/4 (121)	2-1/4 (57)	7/8 (22)	6-3/4 (171)
		26-11/16 (678)	28-5/8 (727)	29 (737)	10 (254)	4-1/2 (114)	6-1/2 (165)	3/8-18	3/8-18											
8	200	HW	6 CYL	8 CYL	HW	6 CYL	8 CYL	6 CYL	8 CYL	8 (203)	13-1/2 (343)	3/4 (19)	2	3/4-10NC	8	11-3/4 (298)	5-3/8 (137)	2-3/4 (70)	1 (25)	9 (229)
		35-15/16 (913)	36-5/8 (930)	37-1/8 (943)	12 (305)	6-1/2 (165)	8-5/8 (219)	3/8-18	3/8-18											
10	250	HW	8 CYL	10 CYL	HW	8 CYL	10 CYL	8 CYL	10 CYL	10 (254)	16 (406)	13/16 (21)	4	7/8-9NC	12	14-1/4 (362)	6-1/8 (156)	2-3/4 (70)	1 (25)	11 (279)
		41-13/16 (1062)	43-3/16 (1097)	43-15/16 (1116)	16 (406)	8-5/8 (219)	10-7/8 (276)	3/8-18	1/2-14											
12	300	HW	8 CYL	10 CYL	HW	8 CYL	10 CYL	8 CYL	10 CYL	12 (305)	19 (483)	3/4 (19)	4	7/8-9NC	12	17 (432)	6-1/8 (156)	3 (76)	1-1/4 (32)	13-1/2 (343)
		47-11/16 (1195)	49-1/8 (1248)	49-7/8 (1267)	16 (406)	8-5/8 (219)	10-7/8 (276)	3/8-18	1/2-14											

Reference Dimensions in (parentheses)

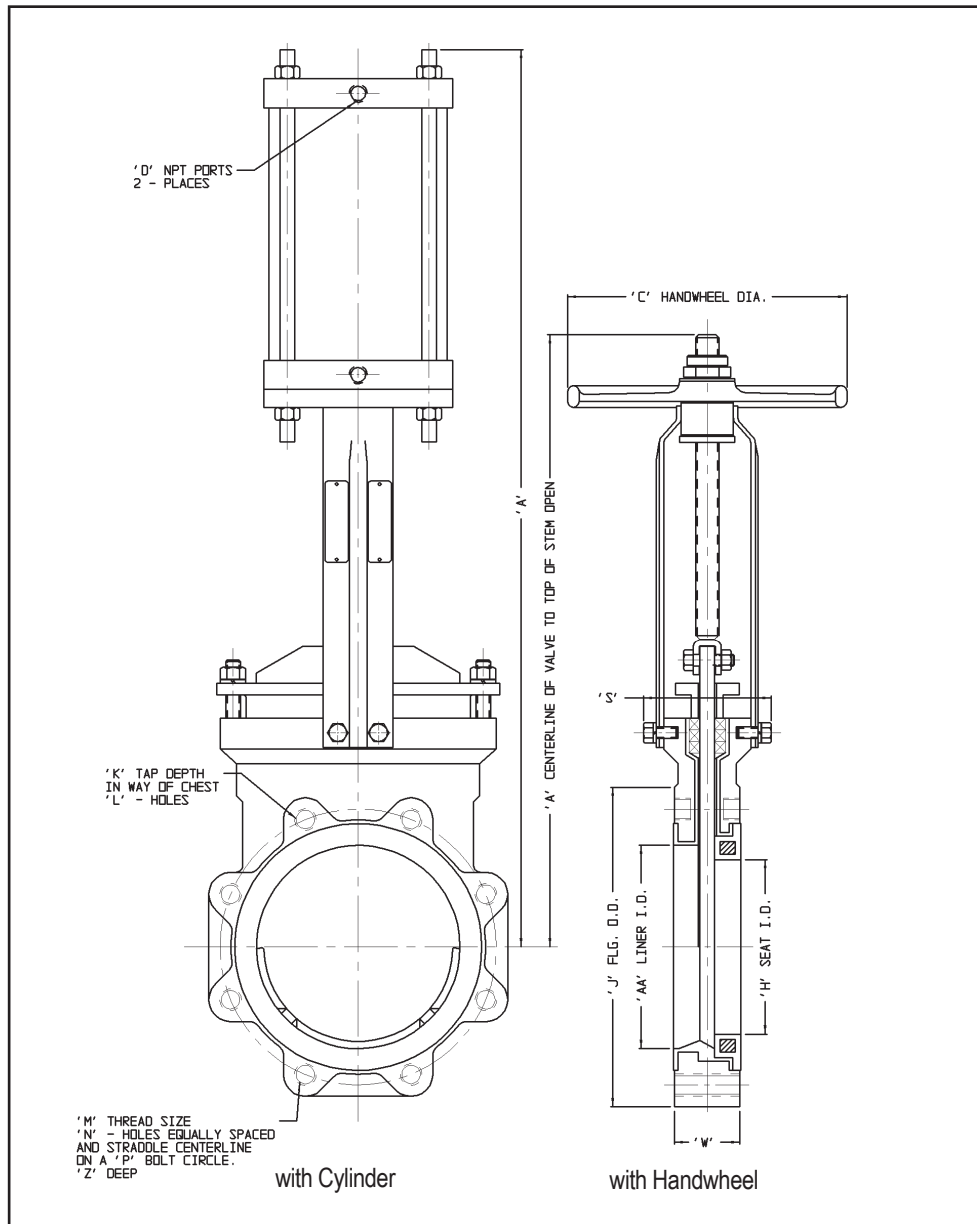



ENGINEERED FOR LIFE

Engineered Valves, LLC
1110 Bankhead Ave
Amory, MS 38821
662.256.7185
www.engvalves.com

© 2012 ITT Engineered Valves, LLC

Form C105