



Fabri-Valve OM150

Urethane Lined Knife Gate Valve



ITT

ENGINEERED FOR LIFE

OM150 Urethane Lined Knife Gate Valve

Zero Discharge Valve

The Fabri-Valve OM150 Urethane Lined Knife Gate Valve provides an economical solution for abrasive and corrosive applications. The OM150 does not discharge process media to the environment. Central to the design of the valve is the most robust perimeter seal in the industry, which provides reliable bi-directional, bubble-tight shutoff.

Each valve is lined with our proprietary urethane material which protects the valve body from the abrasive and corrosive media that the OM150 is designed for. The OM150 body halves are machined to lock in place, the urethane lining that is molded and bonded to each body half. This ensures consistent and repeatable, open and closing gate thrust requirements in any installation. The seal groove is specially designed to prevent seal pull-out but also allows the seal to move and prevent overcompression.



Patented heavy duty, one piece elastomer seal ensures bi-directional, bubble tight, repeatable shut-off. Injectable packing in chest seal is fully enclosed which eliminates possible process fluid contamination by "loose" packing.

Advantages

Hard Urethane Lining:

- Body protection from abrasive and/or corrosive media.
- Mechanically bonded to valve body and is fully supported to prevent lining deflection.
- Provides seat protection from abrasion of direct process flow impingement.
- Molded triple scrapers clean gate during operation to protect integral chest seal.

Patented One-Piece Perimeter & Chest Seal:

- Bi-directional, repeatable shutoff.
- Zero discharge. Zero leakage.
- The perimeter seal has shoulders, which locks the seal in the seal groove even during the most demanding applications.
- Excellent bi-directional shut-off even at very low differential pressure.
- Chest seal wraps around the entire gate eliminating leakage paths.
- Chest seal completely encloses injectable packing eliminating contamination of the process fluid by "loose" packing.

Maintenance:

- Injectable packing allows easy packing adjustments to be made under line pressure without valve disassembly or removal of the valve from the pipeline.

Specifications

Size Range:

DN 50-600 (2" – 24")

Pressure Rating:

10.3 bar (150 psi) CWP (cold working pressure)

Temperature Rating:

77°C (170°F) Standard

Higher temperatures available upon request

Flange Drilling:

ANSI 125/150 Drilling Standard.

Contact factory for alternate flange drilling.

Design

- MSS-SP-81 face to face dimensions.
- Robust gate resists distortion due to effects of water hammer.
- A taper is added to the liner's internal diameter to provide automatic "clean-out" and "flushing".
- Minimized chest area and close tolerances prevents media packing.
- The urethane lining is mechanically bonded and supported by each body half.
- The portion of the lining that interfaces with adjacent pipe flange is slightly raised to provide necessary compression to seal properly. No flange gaskets are necessary.
- Unrestricted straight-through flow design provides true full-port design.
- Non-Rising stem design minimizes space required for installation.
- Universal yoke allows easy conversion between handwheel and cylinder operated.
- Dished handwheel keeps hands away from pinch points while operating.

Flow Coefficients

The Cv values below represent U.S. gallons per minute 60°F water through a 100% open valve at a pressure drop of 1 psi. The metric equivalent, Kv, is the flow of water at +16°C through the valve in cubic meters per hour at a pressure drop of 1 kg/cm².

Valve Size	Cv	Kv
2	299	256
3	876	751
4	2,421	2,075
6	6,231	5,339
8	10,921	9,358
10	16,507	14,145
12	26,649	22,836
14	29,205	25,026
16	41,560	35,613
18	51,356	44,007
20	61,765	52,926
24	83,937	71,926

Testing

Standard shell test:

Hydro test at 1.5 times the rated CWP (cold working pressure)

- Zero allowable leakage

Standard Resilient Seat test:

Hydro test 1 bar (15 psi) and rated CWP.

- Zero allowable leakage

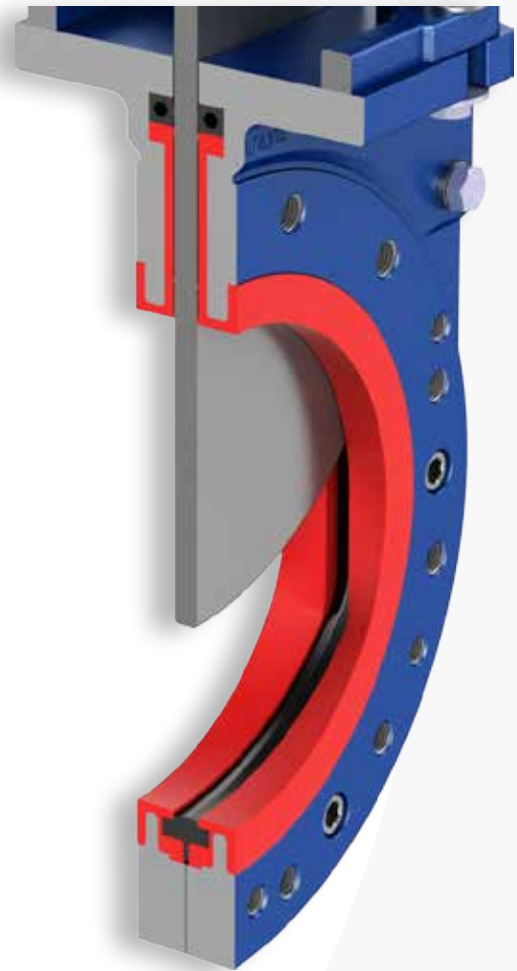

Section view showing fully supported urethane liner and "double locked" one piece perimeter-chest seal.

Dimensions

OM150 with Handwheel or Cylinder

Valve Size		Dimensions Inches (mm) OM150 w/ Handwheel or Cylinder																	
IN	DN	'A'					'C'					'D'							
2	50	HW	4Cyl					HW	4Cyl					HW	4Cyl				
		13.69 (348)	16.81 (427)					10.00 (254)	4.50 (114)						0.88 (48)	3/8-18 (111)			
3	80	HW	5Cyl	6Cyl				HW	5Cyl	6Cyl				HW	5Cyl	6Cyl			
		15.56 (395)	19.75 (502)	20.00 (508)				10.00 (254)	5.50 (140)	6.50 (165)				0.88 (22)	3/8-18	3/8-18			
4	100	HW	5Cyl	6Cyl				HW	5Cyl	6Cyl				HW	5Cyl	6Cyl			
		17.31 (440)	22.50 (572)	22.75 (578)				10.00	5.50	6.50				0.88 (22)	3/8-18	3/8-18			
6	150	HW	5Cyl	6Cyl	8Cyl			HW	5Cyl	6Cyl	8Cyl			HW	5Cyl	6Cyl	8Cyl		
		21.88 (556)	28.00 (711)	28.25 (718)	28.63 (727)			16.00 (406)	5.50 (140)	6.50 (165)	9.00 (229)			1.05 (27)	3/8-18	3/8-18	3/8-18		
8	200	HW	6Cyl	8Cyl	10Cyl			HW	6Cyl	8Cyl	10Cyl			HW	6Cyl	8Cyl	10Cyl		
		25.94 (659)	34.31 (871)	34.69 (881)	35.69 (907)			16.00 (406)	6.50 (165)	9.00 (229)	11.00 (279)			1.1 (28)	3/8-18	3/8-18	1/2-14		
10	250	HW	8Cyl	10Cyl	14Cyl			HW	8Cyl	10Cyl	14Cyl			HW	8Cyl	10Cyl	14Cyl		
		29.50 (749)	40.31 (1024)	41.31 (1049)	43.06 (1094)			16.00 (406)	9.00 (229)	11.00 (279)	14.75 (375)			1.16 (29)	3/8-18	1/2-14	3/4-14		
12	300	HW	8Cyl	10Cyl	14Cyl	16Cyl		HW	8Cyl	10Cyl	14Cyl	16Cyl		HW	8Cyl	10Cyl	14Cyl	16Cyl	
		34.38 (873)	46.69 (1186)	47.69 (1211)	49.69 (1262)	50.00 (1270)		20.00 (508)	9.00 (229)	11.00 (279)	14.75 (375)	17.00 (432)		1.23 (31)	3/8-18	1/2-14	3/4-14	3/4-14	
14	350	HW	8Cyl	10Cyl	12Cyl	14Cyl	16Cyl	HW	8Cyl	10Cyl	12Cyl	14Cyl	16Cyl	HW	8Cyl	10Cyl	12Cyl	14Cyl	16Cyl
			52.00 (1321)	53.00 (1346)	53.00 (1346)	53.88 (1369)	54.19 (1376)		9.00 (229)	11.00 (279)	12.75 (324)	14.75 (375)	17.00 (432)						
16	400	HW	8Cyl	10Cyl	12Cyl	14Cyl	16Cyl	HW	8Cyl	10Cyl	12Cyl	14Cyl	16Cyl	HW	8Cyl	10Cyl	12Cyl	14Cyl	16Cyl
			58.50 (1486)	59.50 (1511)	59.50 (1511)	60.38 (1534)	60.69 (1542)		9.00 (229)	11.00 (279)	12.75 (324)	14.75 (375)	17.00 (432)						
18	450	HW	8Cyl	10Cyl	12Cyl	14Cyl	16Cyl	HW	8Cyl	10Cyl	12Cyl	14Cyl	16Cyl	HW	8Cyl	10Cyl	12Cyl	14Cyl	16Cyl
			63.94 (1624)	64.94 (1649)	64.94 (1649)	65.82 (1672)	66.12 (1679)		9.00 (229)	11.00 (279)	12.75 (324)	14.75 (375)	17.00 (432)						
20	500	HW	10Cyl	12Cyl	14Cyl	16Cyl	18Cyl	HW	10Cyl	12Cyl	14Cyl	16Cyl	18Cyl	HW	10Cyl	12Cyl	14Cyl	16Cyl	18Cyl
			71.19 (1808)	71.19 (1808)	72.06 (1830)	72.38 (1838)	73.38 (1864)		11.00 (279)	12.75 (324)	14.75 (375)	17.00 (432)	19.00 (483)		1/2-14	1/2-14	3/4-14	3/4-14	3/4-14
24	600	HW	10Cyl	12Cyl	14Cyl	16Cyl	18Cyl	HW	10Cyl	12Cyl	14Cyl	16Cyl	18Cyl	HW	10Cyl	12Cyl	14Cyl	16Cyl	18Cyl
			83.31 (2116)	83.31 (2116)	84.19 (2138)	84.50 (2146)	85.50 (2172)		11.00 (279)	12.75 (324)	14.75 (375)	17.00 (432)	19.00 (483)		1/2-14	1/2-14	3/4-14	3/4-14	3/4-14

Valve Size		Dimensions Inches (mm) OM150 w/ Handwheel or Cylinder														
IN	DN	'H'	'K'	'M'	'N'	'P'	'Q'	'R'	'S'	'T'	'U'	'V'	'W'	'X'	'Y'	'Z'
2	50	0.81 (21)	2.00 (51)	6.00 (152)	0.38 (10)	2	N/A	N/A	5/8"-11NC	4	4.75 (121)	.69 (18)	5.13 (130)	1.88 (48)	4.38 (111)	4.38 (111)
		0.88 (22)	3.00 (76)	7.50 (191)	0.38 (10)	2	N/A	N/A	5/8"-11NC	4	6.00 (152)	.75 (19)	5.75 (146)	2.00 (51)	6.13 (156)	6.13 (156)
3	80	0.88 (22)	4.00 (102)	9.00 (229)	0.44 (11)	2	N/A	N/A	5/8"-11NC	8	7.50 (191)	.75 (19)	5.75 (146)	2.00 (51)	6.13 (156)	6.13 (156)
		0.88 (22)	4.00 (102)	9.00 (229)	0.44 (11)	2	N/A	N/A	5/8"-11NC	8	7.50 (191)	.75 (19)	5.75 (146)	2.00 (51)	6.13 (156)	6.13 (156)
4	100	0.88 (22)	4.00 (102)	9.00 (229)	0.44 (11)	2	N/A	N/A	5/8"-11NC	8	7.50 (191)	.75 (19)	5.75 (146)	2.00 (51)	6.13 (156)	6.13 (156)
		0.94 (24)	6.00 (152)	11.00 (279)	0.44 (11)	2	N/A	N/A	3/4-10NC	8	9.50 (241)	.75 (19)	7.38 (187)	2.25 (57)	8.13 (207)	8.13 (207)
6	150	1.19 (30)	8.00 (203)	13.50 (343)	0.46 (12)	2	N/A	N/A	3/4-10NC	8	11.75 (298)	.75 (19)	7.38 (187)	2.75 (70)	9.94 (252)	9.94 (252)
		1.19 (30)	10.00 (254)	16.00 (406)	0.44 (11)	4	N/A	N/A	7/8-9NC	12	14.25 (362)	1.00 (25)	7.38 (187)	2.75 (70)	11.88 (302)	9.94 (252)
8	200	1.25 (32)	12.00 (305)	19.00 (483)	0.50 (13)	4	N/A	N/A	7/8-9NC	12	17.00 (432)	1.125 (29)	7.50 (191)	3.00 (78)	11.69 (297)	9.94 (252)
		1.50 (38)	13.25 (337)	21.00 (533)	0.50 (13)	4	N/A	N/A	1-8NC	12	18.75 (478)	1.125 (29)	10.38 (264)	3.00 (78)	15.50 (394)	15.50 (394)
10	250	1.75 (44)	15.25 (387)	23.50 (597)	0.56 (14)	6	N/A	N/A	1-8NC	16	21.25 (540)	1.25 (32)	10.63 (270)	3.50 (89)	15.50 (394)	15.50 (394)
		1.75 (44)	17.25 (438)	25.00 (635)	0.63 (16)	4	.40 (10)	8	1 1/8-7NC	16	22.75 (578)	1.25 (32)	12.25 (311)	3.50 (89)	15.75 (400)	15.50 (394)
12	300	2.25 (57)	19.25 (489)	27.50 (699)	0.88 (22)	8	0.88 (22)	2	1 1/8-7NC	20	25.00 (635)	1.25 (32)	13.50 (343)	4.50 (114)	17.25 (438)	17.14 (435)
		2.25 (57)	23.25 (591)	32.00 (831)	0.92 (23)	8	0.92 (23)	4	1 1/8-7NC	20	29.50 (749)	1.25 (32)	16.00 (408)	4.50 (114)	21.75 (552)	17.14 (435)

with Handwheel

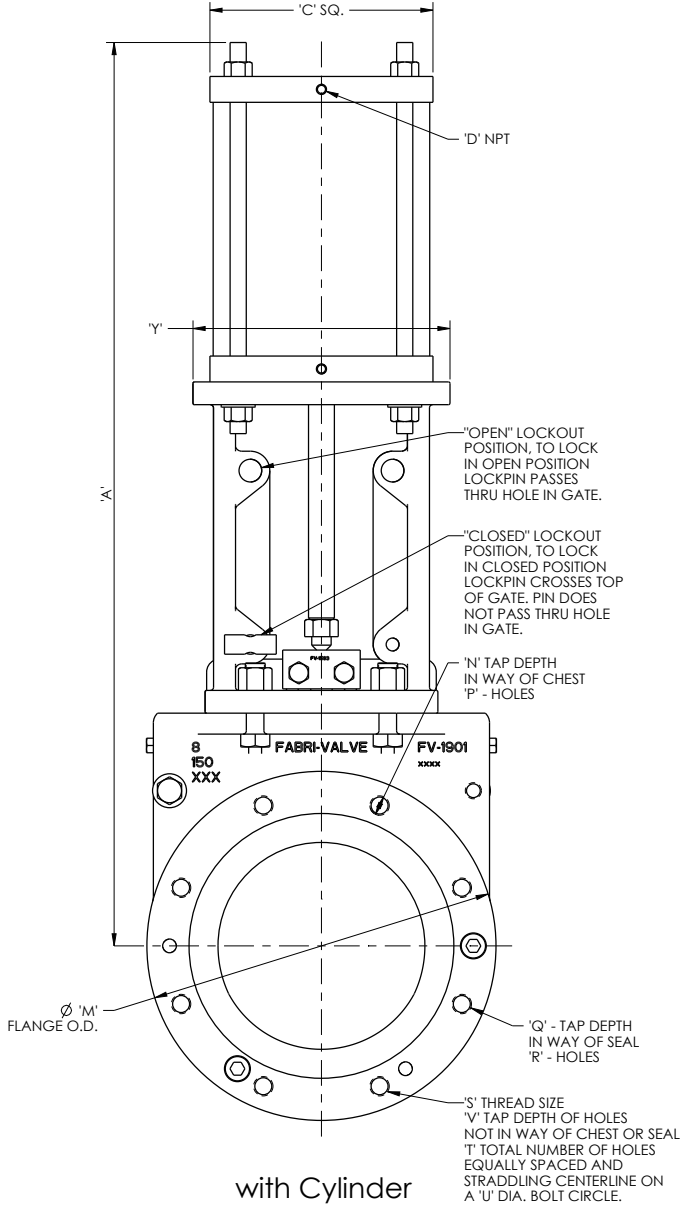
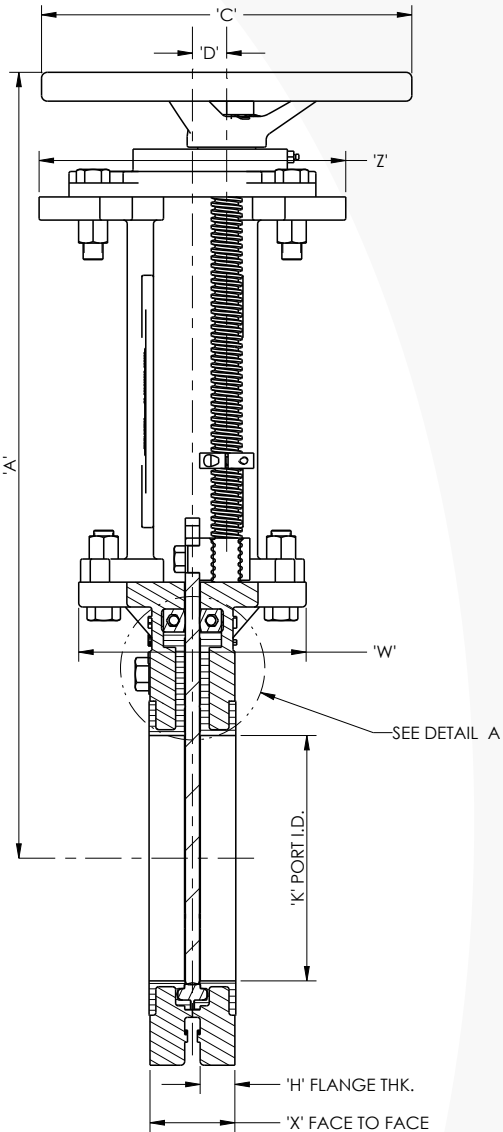

with Cylinder

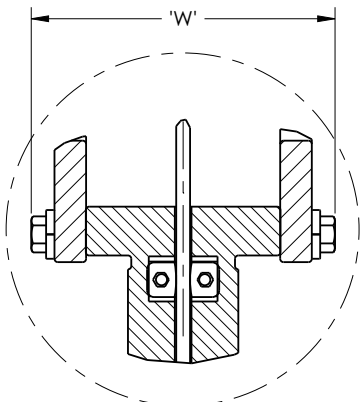

2" - 4" VALVES
SIDE MOUNT YOKE

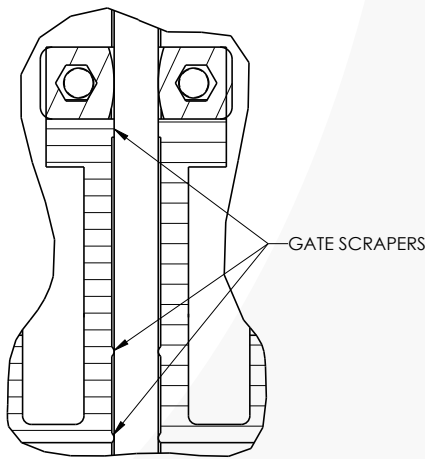

DETAIL A

Dimensions

OM150 with Bevel Gear

Valve Size		Dyna-torque Bevel Gear Model	Dimensions Inches (mm) for OM150 with Bevel Gear																			
IN	DN	Model	'A'	'B'	'C'	'D'	'E'	'H'	'K'	'M'	'N'	'P'	'Q'	'R'	'S'	'T'	'U'	'V'	'W'	'X'	'Y'	'Z'
2	50	BG-3	18.31	16.31	12.00	13.63	3.50	.081	2.00	6.00	0.38	2	N/A	N/A	5/8-11NC	4	4.75	0.69	5.13	1.88	4.38	4.38
		BG-3	(465)	(414)	(305)	(346)	(89)	(21)	(51)	(152)	(10)	2	N/A	N/A	5/8-11NC	4	(121)	(18)	(130)	(48)	(111)	(111)
3	80	BG-3	21.19	18.19	12.00	13.63	3.50	0.88	3.00	7.50	0.38	2	N/A	N/A	5/8-11NC	4	6.00	0.75	5.75	2.00	6.13	6.13
		BG-3	(538)	(462)	(305)	(346)	(89)	(22)	(76)	(191)	(10)	2	N/A	N/A	5/8-11NC	4	(152)	(19)	(146)	(51)	(156)	(156)
4	100	BG-3	24.31	19.94	12.00	13.63	3.50	0.88	4.00	9.00	0.38	2	N/A	N/A	5/8-11NC	8	7.50	0.75	5.75	2.00	6.13	6.13
		BG-3	(617)	(506)	(305)	(346)	(89)	(22)	(11)	(229)	(10)	2	N/A	N/A	5/8-11NC	8	(191)	(19)	(146)	(51)	(156)	(156)
6	150	BG-3	27.44	21.19	12.00	13.63	3.5	0.94	6.00	11.00	0.44	2	N/A	N/A	3/4-10NC	8	9.50	0.81	7.38	2.25	8.13	8.13
		BG-3	(697)	(538)	(305)	(346)	(89)	(24)	(152)	(279)	(11)	2	N/A	N/A	3/4-10NC	8	(241)	(21)	(187)	(57)	(207)	(207)
8	200	BG-3	33.50	25.25	12.00	13.63	3.50	1.19	8.00	13.50	0.46	2	N/A	N/A	3/4-10NC	8	11.75	1.00	7.38	2.75	9.94	9.94
		BG-3	(851)	(641)	(305)	(346)	(89)	(30)	(203)	(343)	(12)	2	N/A	N/A	3/4-10NC	8	(298)	(25)	(187)	(70)	(252)	(252)
10	250	BG-3	39.13	28.81	12.00	13.63	3.50	1.19	10.00	16.00	0.44	4	N/A	N/A	7/8-9NC	12	14.25	1.06	7.38	2.75	11.88	9.94
		BG-3	(994)	(732)	(305)	(346)	(89)	(30)	(254)	(406)	(11)	4	N/A	N/A	7/8-9NC	12	(362)	(27)	(187)	(70)	(302)	(252)
12	300	BG-3	45.50	33.19	12.00	13.63	3.50	1.25	12.00	19.00	0.50	4	N/A	N/A	7/8-9NC	12	17.00	1.125	7.50	3.00	11.69	9.94
		BG-3	(1156)	(843)	(305)	(346)	(89)	(32)	(305)	(483)	(13)	4	N/A	N/A	7/8-9NC	12	(432)	(29)	(191)	(76)	(297)	(252)
14	350	BG-3	50.78	37.19	12.00	13.63	3.50	1.50	13.25	21.00	0.50	4	N/A	N/A	1-8NC	12	18.75	1.125	10.38	3.00	15.50	15.50
		BG-3	(1290)	(945)	(305)	(346)	(89)	(38)	(337)	(533)	(13)	6	N/A	N/A	1-8NC	12	(476)	(29)	(264)	(76)	(394)	(394)
16	400	BG-4	56.31	42.63	12.00	16.25	3.50	1.75	15.25	23.50	0.56	6	N/A	N/A	1-8NC	16	21.25	1.38	10.63	3.50	15.50	15.50
		BG-4	(1430)	(1083)	(305)	(413)	(89)	(44)	(438)	(635)	(14)	6	N/A	N/A	1-8NC	16	(540)	(35)	(270)	(89)	(394)	(394)
18	450	BG-4	61.75	46.04	18.00	16.36	7.00	1.75	17.25	25.00	0.63	4	.4	8	1-1/8-7NC	16	22.75	1.25	12.25	3.50	15.75	15.50
		BG-4	(1568)	(1169)	(457)	(416)	(178)	(44)	(438)	(635)	(16)	4	10	8	1-1/8-7NC	16	(578)	(32)	(311)	(89)	(400)	(394)
20	500	BG-4	68.00	50.29	24.00	17.88	7.00	2.25	19.25	27.50	0.88	8	0.88	2	1-1/8-7NC	20	25.00	1.38	13.50	4.50	17.25	17.14
		BG-4	(1727)	(1271)	(610)	(454)	(178)	(57)	(489)	(699)	(22)	8	0.88	2	1-1/8-7NC	20	(635)	(35)	(343)	(114)	(438)	(435)
24	600	BG-34	80.13	58.44	12.00	18.00	3.50	2.25	23.25	32.00	0.92	8	0.94	4	1-1/4-7NC	20	29.50	1.44	16.00	4.50	21.75	17.14
		BG-34	(2035)	(1484)	(305)	(457)	(89)	(57)	(591)	(813)	(23)	8	0.94	4	1-1/4-7NC	20	(749)	(37)	(406)	(114)	(552)	(435)

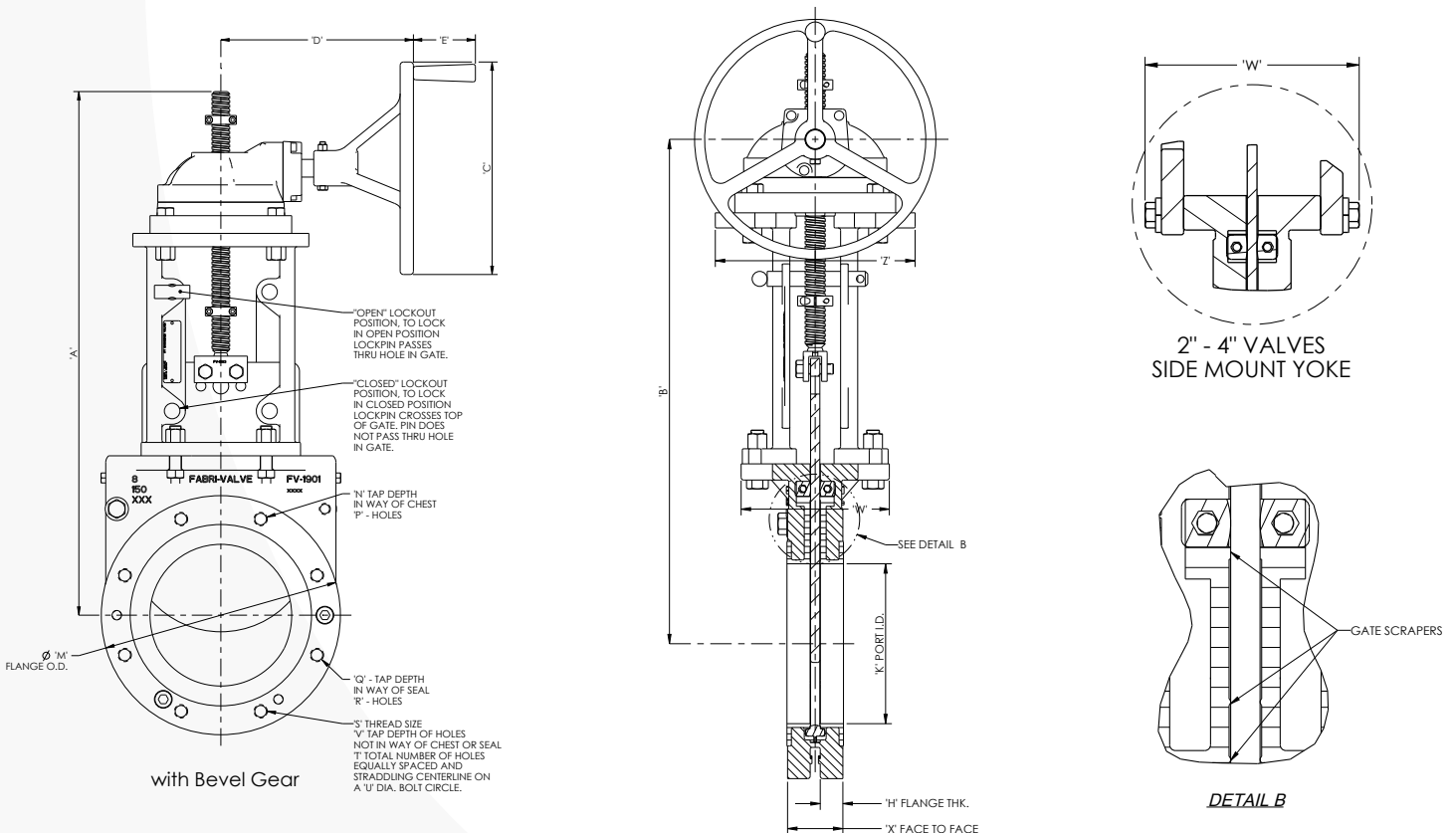

OM150 Diagram and Parts List

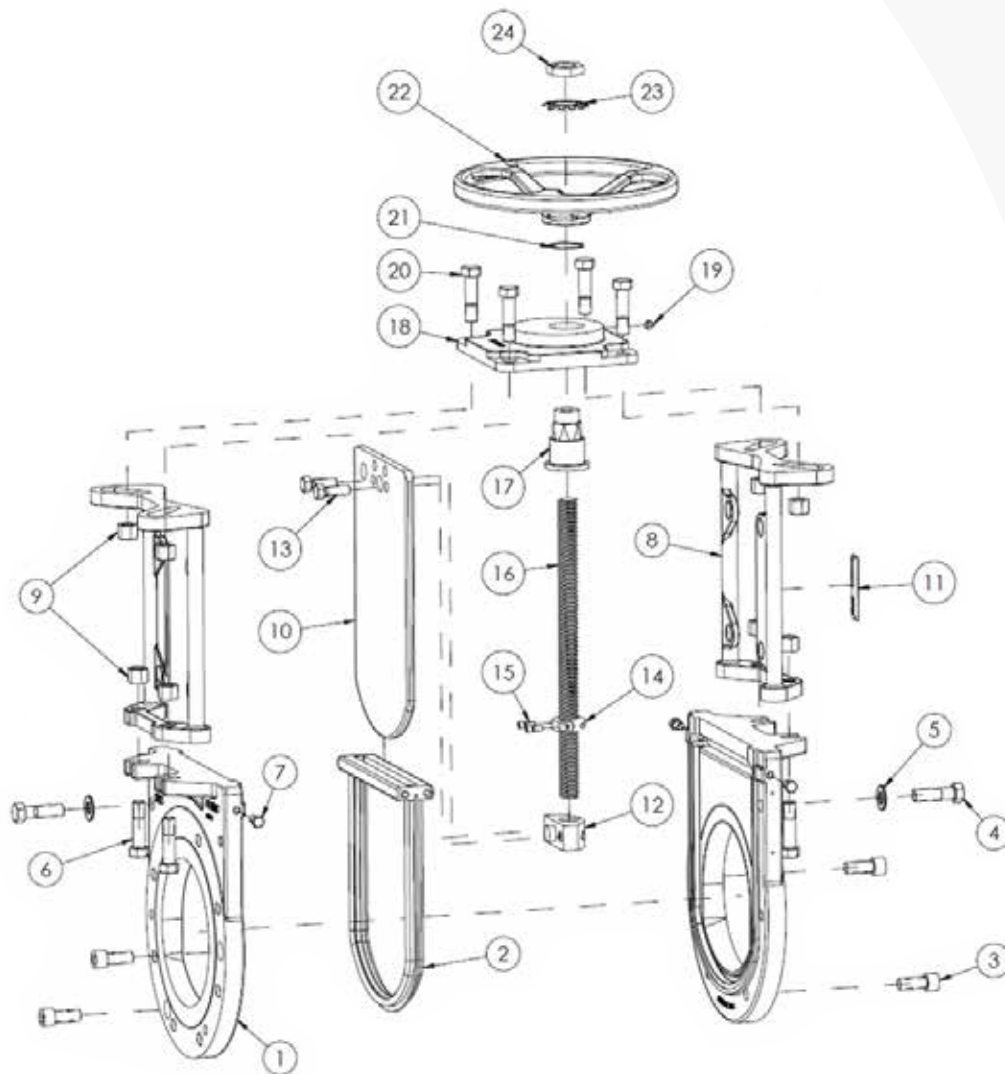

PARTS LIST

ITEM	DESCRIPTION	MATERIAL	ITEM	DESCRIPTION	MATERIAL
1	BODY WITH LINING	CARBON STEEL/URETHANE	13	STEM NUT BOLTS	PLATED STEEL
2	SEAL	EPDM, VITON, AFLAS	14	TRAVEL STOP	STAINLESS STEEL
3	SOCKET HEAD CLAMPING BOLT	STAINLESS STEEL	15	TRAVEL STOP BOLTS	PLATED STEEL
4	CAPSCREW CLAMPING BOLT	STAINLESS STEEL	16	NON RISING STEM	304SS
5	CLAMP BOLT WASHER	STAINLESS STEEL	17	DRIVE NUT	BRONZE
6	YOKE TO BODY BOLT	PLATED STEEL	18	YOKE HUB	CARBON STEEL
7	INJECTION PORT BOLT	STAINLESS STEEL	19	GREASE FITTING	PLATED STEEL
8	YOKE HALF	CARBON STEEL	20	YOKE HUB BOLTS	PLATED STEEL
9	YOKE RETAINER NUT	CARBON STEEL	21	WAVE SPRING	STAINLESS STEEL
10	GATE	SS AS SPECIFIED BY CUSTOMER	22	HANDWHEEL	CAST IRON
11	SERIAL NUMBER TAG	STAINLESS STEEL	23	RETAINER WASHER	STAINLESS STEEL
12	NON RISING STEM NUT	ACID RESISTANT BRONZE	24	RETAINER NUT	PLATED STEEL

Cylinder Sizing (Double Acting/Pneumatic)

Valve Size inches (DN)	Cyl. Air Supply psi (bar)	Differential Pressure - PSI (bar)														
		0-40 (0-2.8)	50 (3.5)	60 (4.1)	70 (4.8)	80 (5.5)	90 (6.2)	100 (6.9)	125 (8.6)	150 (10)	175 (12.1)	200 (13.8)	225 (15.5)	250 (17.2)	275 (19)	285 (19.7)
2 (50)	100 (6.9)	4**	4**	4**	4**	4**	4**	4**	4**	4**	4**	4**	4**	4**	4**	4**
	80 (5.5)	4	4	4	4	4	4	4	4	4	4	4	4	4	4	4
	60 (4.1)	4	4	4	4	4	4	4	4	4	4	4	4	4	4	4
	40 (2.8)	CF	CF	CF	CF	CF	CF	CF	CF	CF	CF	CF	CF	CF	CF	CF
3 (80)	100 (6.9)	5**	5**	5**	5**	5**	5**	5**	5**	5**	5**	5**	5**	5**	5**	5**
	80 (5.5)	5**	5**	5**	5**	5**	5**	5**	5**	5**	5**	5**	5**	5**	5**	5**
	60 (4.1)	5	5	5	5	5	5	5	5	5	5	5	5	5	5	5
	40 (2.8)	6	6	6	6	6	6	6	6	6	6	6	6	6	6	6
4 (100)	100 (6.9)	5**	5**	5**	5**	5**	5**	5**	5**	5**	5**	5**	5**	5**	5**	5**
	80 (5.5)	5	5	5	5	5	5	5	5	5	5	5	5	5	5	5
	60 (4.1)	5	5	5	5	5	5	5	5	5	5	5	5	5	5	5
	40 (2.8)	6	6	6	6	6	6	6	6	6	6	6	CF	CF	CF	CF
6 (150)	100 (6.9)	5	5	5	5	5	5	5	5	5	5	6	6	6	6	8*
	80 (5.5)	5	5	5	5	5	5	5	5	5	6	6	8*	8*	8*	8*
	60 (4.1)	6	6	6	6	6	6	6	6	6	8*	8*	8*	8	8	8
	40 (2.8)	8*	8*	8*	8*	8*	8*	8*	8*	8*	8*	8*	8*	CF	CF	CF
8 (200)	100 (6.9)	6**	6**	6**	6**	6**	6**	6**	6	6	8*	8*	8*	8	8	8
	80 (5.5)	6	6	6	6	6	6	6	6	8*	8*	8*	8	8	10	10
	60 (4.1)	8*	8*	8*	8*	8*	8*	8*	8*	8	8	8	10	10	10	10
	40 (2.8)	8	8	8	8	8	8	8	8	10	10	10	CF	CF	CF	CF
10 (250)	100 (6.9)	8**	8**	8**	8**	8**	8**	8**	8**	8**	8	8	10	10	10	10
	80 (5.5)	8**	8**	8**	8**	8**	8**	8**	8**	8	8	10	10	10	14	14**
	60 (4.1)	8**	8**	8**	8**	8**	8**	8**	8	10	10	10	14**	14**	14	14
	40 (2.8)	10	10	10	10	10	10	10	10	10	14**	14**	14	14	CF	CF
12 (300)	100 (6.9)	8**	8**	8**	8**	8**	8**	8**	8	10	10	10	10	14**	14**	14**
	80 (5.5)	8**	8**	8**	8**	8**	8**	8	10	10	10	14**	14**	14**	14	14
	60 (4.1)	8	8	8	8	8	10	10	10	14**	14**	14	14	14	16	16
	40 (2.8)	10	10	10	10	10	14**	14**	14**	14**	14	14	16	16	CF	CF
14 (350)	100 (6.9)	8**	8**	8**	8**	8	8	8	10	10	12	12	12	14	14	14
	80 (5.5)	8	8	8	8	8	10	10	10	10	12	12	14	14	14	16
	60 (4.1)	10	10	10	10	10	10	10	10	12	14	14	14	16	16	CF
	40 (2.8)	12	12	12	12	12	12	12	14	14	16	16	CF	CF	CF	CF
16 (400)	100 (6.9)	8**	8**	8	8	8	10	10	10	10	12	12	14	14	14	16
	1680 (5.5)	8	8	8	10	10	10	10	10	12	12	14	14	16	16	CF
	60 (4.1)	10	10	10	10	12	12	12	12	14	14	16	16	CF	CF	CF
	40 (2.8)	12	12	12	12	14	14	14	14	16	CF	CF	CF	CF	CF	CF
18 (450)	100 (6.9)	8	8	8	10	10	10	10	10	12	12	14	14	16	16	CF
	80 (5.5)	10	10	10	10	10	10	12	12	14	14	16	16	CF	CF	CF
	60 (4.1)	10	10	12	12	12	12	14	14	16	CF	CF	CF	CF	CF	CF
	40 (2.8)	12	12	14	14	14	16	16	16	CF	CF	CF	CF	CF	CF	CF
20 500)	100 (6.9)	10*	10	10	10	10	12	12	12	12	14	16	16	18	18	18
	80 (5.5)	10	10	10	12	12	12	14	14	14	16	16	18	18	CF	CF
	60 (4.1)	10	12	12	12	14	14	14	16	18	18	CF	CF	CF	CF	CF
	40 (2.8)	14	14	14	16	16	18	18	CF	CF	CF	CF	CF	CF	CF	CF
24 (600)	100 (6.9)	10	10	12	12	12	14	14	16	16	18	18	CF	CF	CF	CF
	80 (5.5)	10	12	12	14	14	14	16	16	18	CF	CF	CF	CF	CF	CF
	60 (4.1)	12	14	14	16	16	16	18	CF	CF	CF	CF	CF	CF	CF	CF
	40 (2.8)	14	16	18	18	CF	CF	CF	CF	CF	CF	CF	CF	CF	CF	CF

CF = Consult Factory

*Cylinder is Oversized. A 7" cylinder is required; however, the factory inventories 8" cylinders.

**Standard factory valve-cylinder combination (Note: Cylinder is slightly oversized).



ENGINEERED FOR LIFE

Engineered Valves, LLC

1110 Bankhead Ave

Amory, MS 38821

Tel: +1 (662) 256-7185

www.engvalves.com